

TU-PGRS-G

UK CA Tension/Compression Load Cell

Introduction

Thank you for purchasing the TU-PGRS-G load cell. Please read this document completely before using this load cell to achieve its best performance and ensure safe and proper operation.

Included accessories

If anything is missing or damaged, contact the retailer where you purchased the product.

- Test report
- Instructions for Use (this document)
- Load button

Company names and product names in this document are the trademarks or registered trademarks of their respective owners.

- Insert screws (steel hexagon socket head cap screws) into the screw holes near the edge of the load cell, and fix it to the flat attachment surface. (Output precision could be affected if the attachment surface is not flat.) The size of the screws used and their number depends on the rated capacity (model name) of the load cell as shown below.

Rated capacity	Screw size	Number	Recommended tightening torque
100 N – 1 kN	M4 × 35	3	3 N·m
2 kN – 5 kN	M6 × 50	6	8 N·m
10 kN – 20 kN	M8 × 60	6	30 N·m

Use screws with a strength grade of 12.9. In addition, the length of thread engagement for the screw and the mounting part (internal threads) should be about twice the nominal diameter of the screw. Please consult with us if you are uncertain about screw selection, for example.

- Since tightening screws will cause their heads to contact the coated surface of the load cell, which could scrape the coating, use flat washers with the screws so that the washers contact the load cell instead. Even using flat washers, the coating could be scraped if the flat washers are turned. By using a metal washer like the one shown in the illustration below, you can avoid scraping the coating even more.

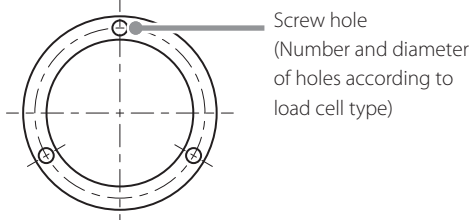

IMPORTANT SAFETY INSTRUCTIONS

WARNING

If something abnormal occurs

Request repair from the retailer where you purchased the product.

Do not open the cover.

Never remove the cover from this unit. Doing so could cause malfunction. Request inspection and repair from the retailer where you purchased the product. Do not alter this unit. Doing so could cause malfunction.

Do not put foreign objects or water, for example, into the unit.

Do not place a container that holds water, for example, on top of this unit. If liquid is spilled, for example, and enters the unit, this could cause malfunction.

Do not use the unit with any power supply voltage other than that specified.

Do not use the unit with any power supply voltage other than that specified. Doing so could cause malfunction.

CAUTION

Unsuitable installation locations

Do not place the unit in the following types of locations. Doing so could cause malfunction.

- Locations where it might be exposed to smoke or steam, such as near a kitchen table or humidifier
- Unstable locations, including unsteady stands and tilted places
- Locations that are very humid or dusty
- Locations that are exposed to direct sunlight

When not using the unit for a long time

For safety, cut the power supply when not using this unit for a long time.

Do not operate a damaged unit.

Precautions for use

- This unit is not built to be water or splash resistant, and it cannot be used in conditions when the relative humidity is high. Moreover, use in atmospheres with corrosive gases should be avoided.
- Be careful to prevent water, oil and other substances from getting on the unit.
- Avoid use in conditions where condensation could occur.
- Connect cores to the load cell after discharging (eliminating) static electricity from your body.
- If the surrounding temperature changes suddenly, the values output by this device could become unstable, making accurate measurement impossible. (This could occur, for example, in a location blown by warm or cold air.)
- Conduct load calibrations periodically.

Installation procedures

- Attach the load button when using with compression. Tighten with the torque shown in the table below to prevent the load button from becoming loose. When removing an attached load button, be sure not to apply torque that exceeds the tightening torque shown in the table.

Rated capacity	Tightening torque	Load button screw dimension
100 N – 1 kN	3 N·m	M8
2 kN – 5 kN	3 N·m	M12
10 kN – 20 kN	3 N·m	M18

A thread-locking fluid can be used on the screw, but be aware that this could prevent removal of the load button.

- When using with a tensile load, attach a rod end or tensile load adapter.

- When attaching a rod end to a load cell, use a nut to prevent loosening. When tightening this nut for the prevention of loosening, do not allow the counterforce to be applied to the load cell. (Do not hold the entire load cell in place while tightening the nut.) If twisting force is applied between the central screw part and the surrounding screw holes, that force could be transferred to the load detection part and damage it. For this reason, when attaching the nut, hold the rod end side in place.

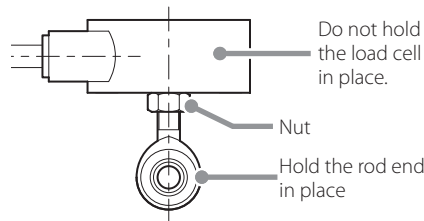

- In addition, always use screws that are suitable for the rated capacity when attaching a base plate or tensile load adapter, for example, to a load cell. Use flat washers together with these screws (see the illustration below). When tightening the rod end nut, do not let the counterforce be applied to the load cell. (Hold the rod end side.) Moreover, tighten each of the attachment screws evenly.

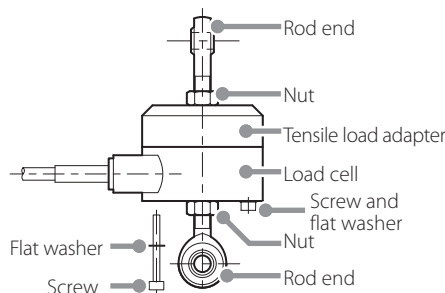

- As shown in the illustration below, there is a level change between the outer circumference and the central screw portion of the load cell attachment surface. This gap functions as a stopper when the load cell is overloaded in the compression direction. For this reason, be aware that if the attachment surface is uneven, rough, dusty or dirty, for example, the stopper could function at a load lower than the rated capacity and produce inaccurate measurement results.

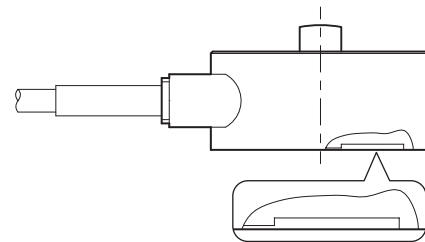

Precautions when placing loads on the unit

- Make sure the load is perpendicular to the surface to which this unit is attached.
- Apply the load so that it is centered on the center of the unit. If the load is not centered (eccentric load), twisting, for example, and measurement errors could occur. This could even result in damage.

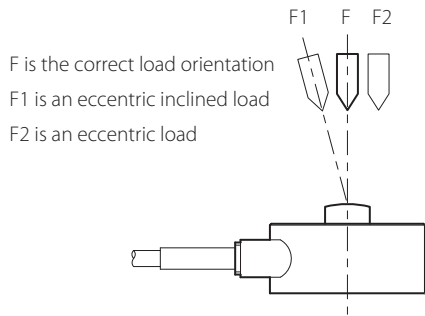

- If the load receiving area is contacted by something that is at a different temperature and the load is increased, the values output by this device could become unstable, making accurate measurement impossible. In such a case, wait until the temperature difference ceases to exist before measuring.

Electrical connection of load cell

- Connect as shown in the illustration below. Incorrect connections could result in inability to balance and in errors occurring in the output voltage when loads are applied.

Using a cable with bare lead wires

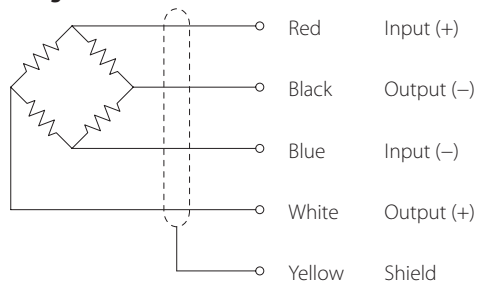

- This unit does not support remote sense. See the operation manuals of indicators and strain amps that support remote sense for how to connect sensors with those units.
- The shield is not connected to the main body of this product. For this reason, if grounding is necessary because of external noise or another issue, arrange to ground the shield to a part other than the body of this unit, for example.
- Since the cable is directly connected to this unit, use a specialized cable to increase the length. (Please consult with us.)

Using a connector (optional)

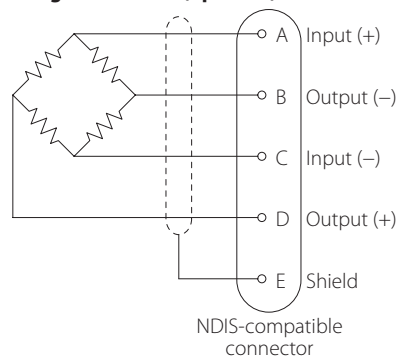

Handling after use

- When moving this unit while it is installed, take protective measures to prevent it from being shaken or subjected to excessive external forces.
- When storing it, keep it in a dry place where it will not be exposed to water or oil, for example.

Specifications

TU-PGRS 100N-G to TU-PGRS 20KN-G
Rated capacity: 100 N, 200 N, 500 N, 1 kN, 2 kN, 3 kN, 5 kN, 10 kN, 20 kN
Safe overload rating: 150% R.C.
Rated output: 2 mV/V ±0.3%
Linearity: 0.03% R.O.
Hysteresis: 0.03% R.O.
Repeatability: 0.02% R.O.
Zero balance: 3% R.O.
Safe excitation voltage: 15 V (100 N, 200 N)
20 V (500 N – 20 kN)
Input terminal resistance: 1050 ±10 Ω
Output terminal resistance: 1050 ±10 Ω
Insulation resistance: 1000 MΩ or more (DC 50 V)
Compensated temperature range: -10 to 60°C
Permissible temperature range: -30 to 80°C
Temperature effect on zero balance: 0.025% R.O./10°C
Temperature effect on output: 0.03% R.O./10°C
Cable: Ø6mm 4-core shielded cable, 5m direct connection with bare lead wires (100 N – 5 kN)
Ø8mm 4-core shielded cable, 5m direct connection with bare lead wires (10 kN, 20 kN)
Body material: aluminum (coated surface) (100 N – 5 kN)
Steel (coated surface) (10 kN, 20 kN)
Environmental compliance: RoHS (10 substances)
TEDS: not supported
Other: load button included

Dimensional drawings (dimensions in millimeters (mm))

TU-PGRS 100N-G to TU-PGRS 1KN-G

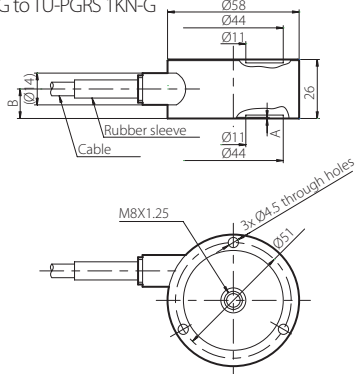

Rated capacity	A	B
100 N	0.15	13
200 N	0.15	13
500 N	0.09	11.5
1 kN	0.09	11.5

TU-PGRS 2K-G to TU-PGRS 5KN-G

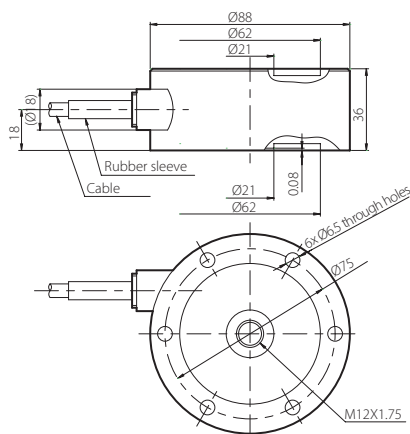

TU-PGRS 10K-G to TU-PGRS 20KN-G

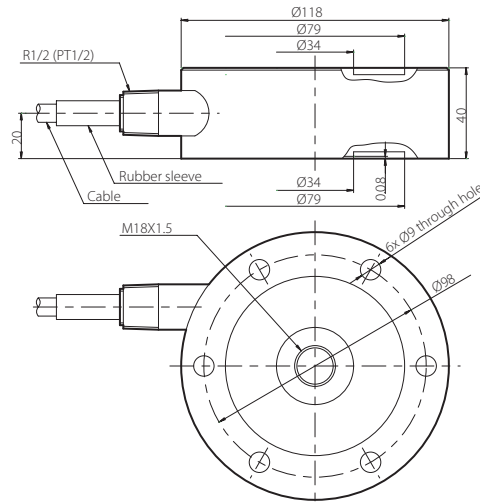

Warranty explanation

- The warranty period for this device is one year from the date of purchase.
 - 1) Be aware that repairs will require payment in the following cases even during the warranty period. Malfunction or damage due to misuse
 - 2) Malfunction or damage caused by modifications or repairs conducted by any party other than our company or a service person designated by our company
 - 3) Malfunction or damage caused by dropping, transportation or similar handling after product delivery
 - 4) Malfunction or damage caused by fire, earthquake, water, lightning or other natural disaster
 - 5) Malfunction or damage caused by external factors, including power supplies and equipment environmental conditions, that deviate from the operation

requirements of this product

- 6) Malfunction or damage if the product was not purchased from our company or an agent designated by our company
- We offer paid service after the conclusion of the warranty period. For details, please contact the retailer where you purchased the unit.
 - Be aware that our company will bear no responsibility for any secondary damages resulting from the operation of this device or related to data.
 - Information is given about products in this manual only for the purpose of example and does not indicate any guarantees against infringements of third-party intellectual property rights and other rights related to them. TEAC Corporation will bear no responsibility for infringements on third-party intellectual property rights or their occurrence because of the use of these products.

Contact information

TEAC CORPORATION (Manufacturer)

1-47 Ochiai, Tama-shi, Tokyo 206-8530 Japan
Phone: +81-042-356-9154

TEAC AMERICA, INC.

10410 Pioneer Blvd. Suite #1, Santa Fe Springs, California 90670, U.S.A.
Phone: +1-323-726-0303

TEAC EUROPE GmbH. (EU Importer)

Bahnstrasse 12, 65205 Wiesbaden-Erbenheim, Germany
Phone: +49-611-7158-349

TEAC UK Limited (UK Importer)

Luminous House, 300 South Row, Milton Keynes, Buckinghamshire, MK9 2FR, UK
Phone: +44-1923-797205