

Features

High Precision Heavy Duty  
**Accurate, Rugged**  
 Coin-size  
**and Compact**

### Compression Load Cell



**Built-in Anti Overload System**

Easy to install on the existing facilities/systems.

**Durable Robot Cable standardized**

Enhanced durability against bending that occurs in moving parts with frequent repetitive motion, such as industrial robots and machine tools. High stability and reliability are realized.

**Plug & Play with built-in TEDS**

With the TD series indicators, equivalent input calibration, likely to forget in manual setting, can be performed automatically and help prevention. (See the reverse page for detail on TEDS)

#### Specifications

Type	Compression Load Cell															
Model	<b>TC-USR(T)□□N/KN-G3</b>										<b>TEDS</b> (Embedded in the body)			<b>RoHS</b> (10 substances)		
Line up (SKU)	<b>TC-USR(T)30-G3</b>		<b>TC-USR(T)17-G3</b>			<b>TC-USR(T)23-G3</b>			<b>TC-USR(T)29-G3</b>				<b>TC-USR(T)34-G3</b>			
Rated Capacity (R.C.)	0.5N	1N	1N	2N	5N	1N	2N	5N	10N	20N	50N	100N	200N	500N	1kN	2kN
Natural Frequency	0.5kHz	0.8kHz	6.7kHz	5.6kHz	6.7kHz	7.1kHz	5.5kHz	7.5kHz	6.8kHz	7.5kHz	9.5kHz	15kHz	14kHz	14kHz	15kHz	16kHz
Weight	12g		2.5g			5g			15g		35g		58g		65g	
Nominal Diameter	Ø30 type		Ø17 type			Ø23 type			Ø29 type				Ø34 type			
Body Material	Aluminum									Stainless Steel						
Safe overload rating	120% R.C.			150% R.C.												
Overload Limit	300% R.C.			500% R.C.						300% R.C.						
Rated Output (R.O.)	0.5mV/V or more					about 0.4mV/V (17/23-1N)				0.75mV/V or more						
Linearity	0.1% R.O.		0.3% R.O.						0.1% R.O.							
Hysterisis	0.1% R.O.		0.3% R.O.						0.1% R.O.							
Repeatability	0.1% R.O.		0.3% R.O.						0.1% R.O.							
Safe Excitation Voltage	6V															
Input Terminal Resistance	420±20Ω		370±20Ω (17-1N)			370±20Ω (23-1N)			390±20Ω							
Output Terminal Resistance	350±20Ω															
Insulation Resistance	1000MΩ or more (50V DC)															
Compensated Temperature Range	0°C to 60°C															
Permissible Temperature Range	-5°C to 70°C			-10°C to 60°C												
Temperature Effect on Zero Balance	0.5% R.O. / 10°C (17/23-1N), 0.3% R.O. / 10°C															
Temperature Effect on Output	0.3% R.C. / 10°C			0.1% R.C. / 10°C												
Cable	Φ3, 6-core shielded, 3m direct connection robot cable with bare lead wires															
Mounting Method	Screw hole except the Φ17 type which is glue type															
Construction	Built-in Anti Overload System															

Dimensional drawings  
(Units: mm)

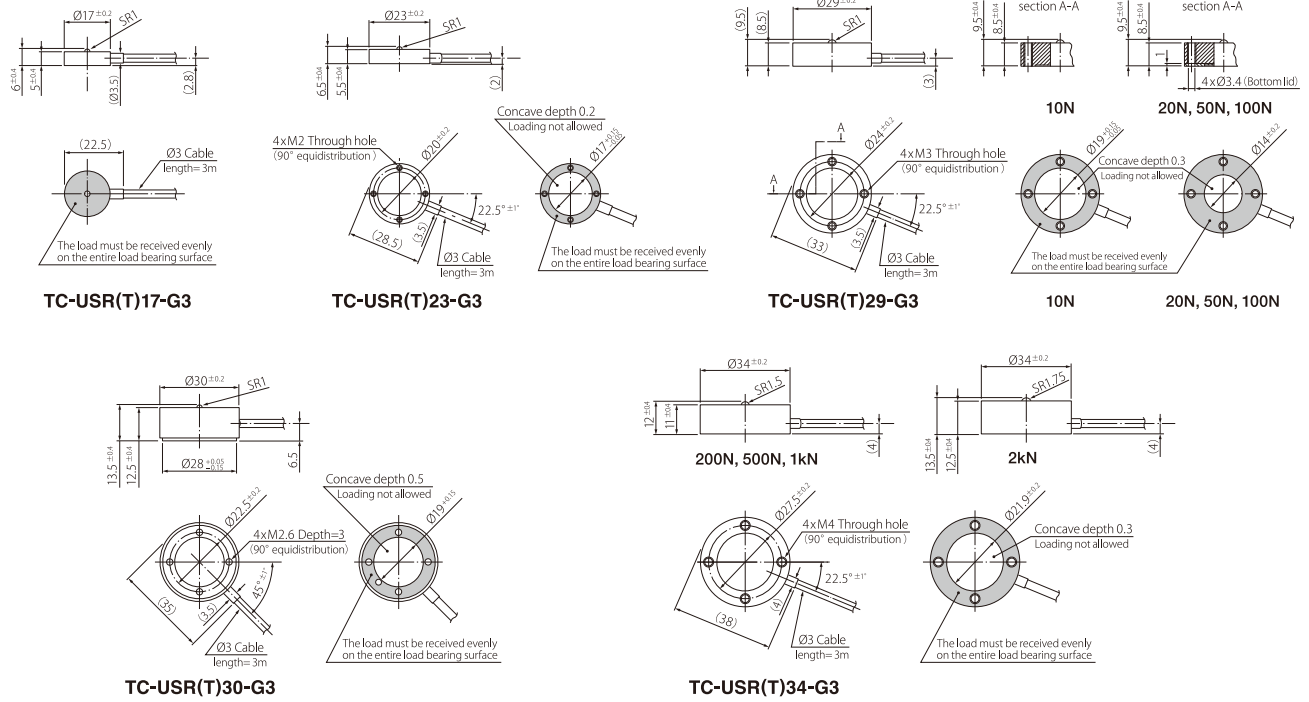

Advantages of the TEAC Load Cells

TEAC Load Cells

Since we started manufacturing load cells, a number of load cells that achieve high response, high accuracy, and high stability, as well as products that take environmental conservation into consideration have been developed. We also offer customization for specific conditions (usage environment, space) that are difficult to meet with standard ones. From one-off prototypes to mass production, we support engineers involved in research and development on manufacturing technology.

Robot Cable standardized

Robot cables provide enhanced durability and stable performance against bending that occurs in moving parts with frequent repetitive motion, such as industrial robots and machine tools. With the TEDS, it allows you to save your time and reduce processes.

\* Customized proposals that match your application and environment are available. Please contact our sales representatives for detail.

TEDS-compatible

The TEDS (Transducer Electronic Data Sheet) system electronically reads and writes sensor's specific characteristic such as model name, serial number, sensitivity (output value against physical quantity) and other calibration factors digitized and recorded in the load cell, allowing you to automate the reading of recorded information and equivalent input calibration, while eliminating human error in setting and reducing the burden of load cell replacement.

Related Products (Indicators and Signal Conditioners)



**New**  
EtherNet/IP model  
CC-Link model

92 x 92mm  
Panel opening size

Color Graphics Digital Indicator

**TD-9000T**

RS-485 model  
EtherNet/IP™ model  
CC-Link model

High performance model with large LCD

Supporting two inputs, force sensor and displacement sensor, various comparison judgments function, and direct saving of waveform data onto large capacity internal memory.



92 x 45mm  
Panel opening size

Digital Indicator

**TD-700T**

Standard model  
CC-Link model  
RS-485 model

Excellent model with compact and high functionality

Supporting five key functions in one unit, numeric display, graph display, TEDS function, static strain display, and signal conditioner. This small and cost-effective TD-700T achieves equal or even higher performance to upper-class models, with high-visibility color LCD and various hold functions.



**New**  
Attaches to common DIN rails

Signal Conditioner

**TD-SC1**

D/A model EtherNet/IP™ model  
RS-485 model CC-Link model

Slim and light-weight signal conditioner

Supporting high-speed sampling of 20,000 times/second, PC-based configuration via USB connection, selectable network, and TEDS calibration function.



Weights only 320g (incl. batteries)

Portable Digital Indicator

**TD-01 Portable**

On-site checking tool with versatility

Supporting various functions that equal to embedded systems, in hand-held size, allowing you to take measurements anytime anywhere, according to your purpose.



EtherNet/IP is a trademark of ODVA, Inc. Other company names, product names and logos in this document are the trademarks or registered trademarks of their respective holders.

TEAC CORPORATION

1-47 Ochiai, Tama-shi, Tokyo  
206-8530, Japan

E-mail: cs\_ipd@teac.jp  
Web: https://loadcell.jp/en/

TEAC America, Inc.,  
E-mail: datarecorder@teac.com

TEAC EUROPE GmbH.  
E-mail: info@teac.eu

TEAC SALES & TRADING (ShenZhen) CO., LTD.  
E-mail: teacservice3@teac.com.cn