

TC-PF2(T)-G



Compression Load Cell

Introduction

Thank you for purchasing the TC-PF2(T)-G load cell. Please read this document completely before using this load cell to achieve its best performance and ensure safe and proper operation.

- Company names and product names in this document are the trademarks or registered trademarks of their respective owners.

Included accessories

If anything is missing or damaged, contact the retailer where you purchased the product.

- Test report × 1
- Instructions for Use (this document) × 1
- Adhesive tape for attachment × 2

IMPORTANT SAFETY INSTRUCTIONS

WARNING

If something abnormal occurs

Request repair from the retailer where you purchased the product.

Installation procedures

- Install this unit in a place where the structure is level and can sufficiently bear the load being used.
- When attaching this load cell to a surface that is not flat, such as a brake pedal, utilize a spacer that is sufficiently stiff between it and the pedal so that it can be attached to a flat surface.
- To attach this load cell to a brake pedal, attach the prepared spacer to the load cell and then use the provided adhesive tape to attach it to the brake pedal. (See the illustration below.)

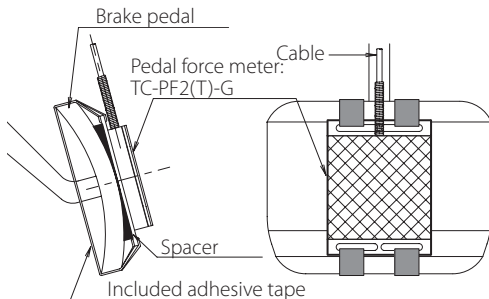

ATTENTION

Attaching this load cell to the curved surface of a pedal without using a spacer could cause force to be applied to part of its bottom, causing measurement not to be accurate and even damaging it.

- When attaching this load cell, consider the orientation of the connected cable so that it does not obstruct operation of the pedal, for example. Attach the cable to the pedal stay or similar location so that it does not move with vibration, for example.
- When using it, always thoroughly verify that it will not become displaced or detached.

Do not open the cover.

Never remove the cover from this unit. Doing so could cause malfunction. Request inspection and repair from the retailer where you purchased the product. Do not alter this unit. Doing so could cause malfunction.

Do not put foreign objects or water, for example, into the unit.

Do not place a container that holds water, for example, on top of this unit. If liquid is spilled, for example, and enters the unit, this could cause malfunction.

Do not use the unit with any power supply voltage other than that specified.

Do not use the unit with any power supply voltage other than that specified. Doing so could cause malfunction.

CAUTION

Unsuitable installation locations

Do not place the unit in the following types of locations. Doing so could cause malfunction.

- Near a power line
- Locations where strong magnetic fields exist or magnetic fields could occur
- Where static electricity or noise, (for example, from a relay) is generated
- Locations subject to temperatures exceeding the specified temperature and humidity ranges
- Locations subject to direct vibration or shock
- Locations subject to radiant heat from heat sources
- Locations exposed to dirt and dust
- Locations subject to severe temperature changes
- Locations that could freeze
- Locations where liquid, for example, could enter the unit as well as locations with high humidity where condensation could occur
- Locations where it might be exposed to smoke or steam, such as near a kitchen table or humidifier

Precautions in spacer design

- Keep in mind that the spacer should conform to the shape of the pedal to fill in any gap between it and this load cell. The spacer should enable attachment of this load cell to a flat surface regardless of the shape of the pedal. The form should also enable secure attachment.
- The M3 screw holes on the back of this load cell can be used to attach it and the spacer. This screw depth is 2 mm. The screw hole is open-ended, so if the screw depth exceeds 2 mm, the tip of the attachment screw could penetrate the inside and contact the interior structure causing damage. Please use caution.

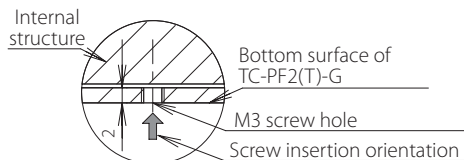

- Please contact the retailer where you purchased the unit if you have any uncertainties about spacers.

- Unstable locations, including unsteady stands and tilted places
- Locations that are very humid or dusty
- Locations that are exposed to direct sunlight

When not using the unit for a long time

For safety, cut the power supply when not using this unit for a long time.

Do not operate a damaged unit.

Precautions for use

- This unit is not built to be water or splash resistant, and it cannot be used in conditions when the relative humidity is high. Moreover, use in atmospheres with corrosive gases should be avoided.
- Be careful to prevent water, oil and other substances from getting on the unit.
- Avoid use in conditions where condensation could occur.
- Connect cores to the load cell after discharging (eliminating) static electricity from your body.
- If the surrounding temperature changes suddenly, the values output by this device could become unstable, making accurate measurement impossible. (This could occur, for example, in a location blown by warm or cold air.)
- If a cable of this unit needs to be bent and shifted, make the curvature of the bent part at least 50 mm. Do not apply tension to the cable.
- Conduct load calibrations periodically.

Precautions when placing loads on the unit

- Make sure the load is perpendicular to the surface to which this unit is attached.
- Apply the load so that it is centered on the center of the unit. If the load is not centered (eccentric load), twisting, for example, and measurement errors could occur. This could even result in damage.

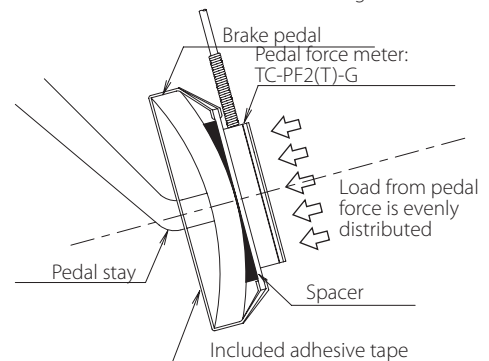

- Be careful to avoid turning and twisting from lateral loads. This could cause troubles like those described in the previous item.
- Be careful to avoid applying loads that exceed the rated capacity. In particular, use caution when there are vibrations because loads that exceed the rated capacity could occur due to sympathetic vibrations, for example.
- If the load receiving area is contacted by something that is at a different temperature and the load is increased, the values output by this device could become unstable, making accurate measurement impossible. In such a case, wait until the temperature difference ceases to exist before measuring.

Electrical connection of load cell with built-in TEDS

- Connect as shown in the illustration below. Incorrect connections could result in inability to balance and in errors occurring in the output voltage when loads are applied.

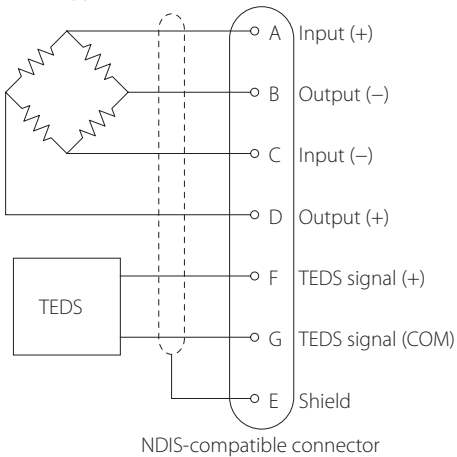

- Connect cores to the load cell after discharging (eliminating) static electricity from your body.
- This unit has a built-in TEDS function. The F and G pins in the connector are wired for TEDS.
- This unit does not support remote sensing. See the operation manuals of indicators and strain amps that support remote sensing for how to connect sensors with those units.
- The shield is not connected to the main body of this product. For this reason, if grounding is necessary because of external noise or another issue, arrange to ground the shield to a part other than the body of this unit, for example.

- Specifications and appearance are subject to change without notice.
- Weight and dimensions are approximate.
- Illustrations in this owner's manual might differ slightly from production models.

Dimensional drawings

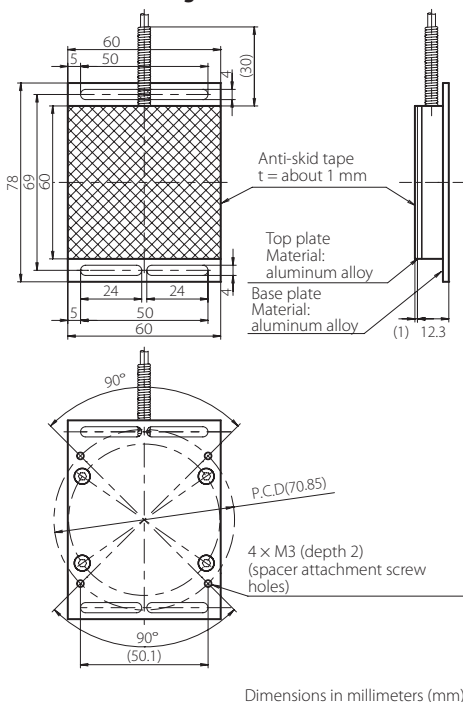

- See external dimension illustration for details.

- Since the cable is directly connected to this unit, use a specialized cable to increase the length. (Please consult with us.)
- When conducting insulation resistance tests, limit them to connector pins A, B, C and D. Do not apply to pins F and G.

TEDS overview

TEDS (Transducer Electronic Data Sheet) is a memory chip that can electronically read and write sensor-specific data. The TEDS built into this unit has serial number, load cell rated output and manufacturer name data recorded on it. By connecting an indicator that supports TEDS, the TEDS data of the connected load cell will be automatically read and equivalent input calibration will be completed. (For details, read the operation manual of the connected indicator.) Refer to the connection diagrams in "Electrical connection of load cell with built-in TEDS" as well as the operation manual for the indicator being connected for procedures to make connections.

TEAC indicators and signal conditioners that support TEDS include the TD-01 Portable, TD-700T, TD-260T, TD-9000T and TD-SC1. For details, inquire at the retailer where you purchased the unit.

Moreover, take measures to prevent the orange and green cores from touching other terminals.

Data recorded in TEDS are tested values from calibration conducted at room temperature during inspection before shipping from our company.

Load cell output will be affected by the environmental temperature where used, even when within the compensated temperature range established in the specifications. Although load cell output is calculated from the calibration value saved in TEDS, when the environmental temperature differs greatly from room temperature, the temperature

impacts increase on the zero point and the output. For this reason, consideration of the effect on output voltage is necessary. Output voltage changes will be within the specification range as long as the unit is used at temperatures within the specification range.

Handling after use

- When moving this unit while it is installed, take protective measures to prevent it from being shaken or subjected to excessive external forces.
- When storing it, keep it in a dry place where it will not be exposed to water or oil, for example.

Specifications

Rated capacity: 500 N, 1 kN, 2 kN

Safe overload rating: 150% R.C.

Rated output: about 1 mV/V

Linearity: 0.3% R.O.

Hysteresis: 0.3% R.O.

Repeatability: 0.2% R.O.

Zero balance: $\pm 10\%$ R.O.

Safe excitation voltage: AC/DC 8V

Input terminal resistance: $700 \Omega \pm 5\%$

Output terminal resistance: $700 \Omega \pm 5\%$

Insulation resistance: 1000 M Ω or more

Compensated temperature range: 0 to 50°C (no condensation)

Permissible temperature range: -10 to 70°C

Temperature effect on zero balance: 0.5% R.O./10°C

Temperature effect on output: 0.5% R.C./10°C

Cable: $\varnothing 3$ mm 6-core shielded robot cable

3 m direct connection with NDI7P on the tip

NDI7P: PRC03-12A-10-7M

Environmental compliance: RoHS (10 substances)

Other: TEDS built into NDI7J (PRC03-12A-10-7M)

Warranty explanation

- The warranty period for this device is one year from the date of purchase.
- Be aware that repairs will require payment in the following cases even during the warranty period.

- Malfunction or damage due to misuse
- Malfunction or damage caused by modifications or repairs conducted by any party other than our company or a service person designated by our company
- Malfunction or damage caused by dropping, transportation or similar handling after product delivery
- Malfunction or damage caused by fire, earthquake, water, lightning or other natural disaster
- Malfunction or damage caused by external factors, including power supplies and equipment environmental conditions, that deviate from the operation requirements of this product
- Malfunction or damage if the product was not purchased from our company or an agent designated by our company

- We offer paid service after the conclusion of the warranty period. For details, please contact the retailer where you purchased the unit.

- Be aware that our company will bear no responsibility for any secondary damages resulting from the operation of this device or related to data.

- Information is given about products in this manual only for the purpose of example and does not indicate any guarantees against infringements of third-party intellectual property rights and other rights related to them. TEAC Corporation will bear no responsibility for infringements on third-party intellectual property rights or their occurrence because of the use of these products.

Contact information

TEAC CORPORATION (Manufacturer)

1-47 Ochiai, Tama-shi, Tokyo 206-8530 Japan

Phone: +81-042-356-9154

TEAC AMERICA, INC.

10410 Pioneer Blvd. Unit #1, Santa Fe Springs, California 90670, U.S.A.

Phone: +1-323-726-0303

TEAC EUROPE GmbH. (EU Importer)

Bahnstrasse 12, 65205 Wiesbaden-Erbenheim, Germany

Phone: +49-611-7158-349

TEAC UK Limited (UK Importer)

Luminous House, 300 South Row, Milton Keynes,

Buckinghamshire, MK9 2FR, UK

Phone: +44-1923-797205