

TEAC**Strain gauge load cell Instructions for Use****TC-FSRSP(T)-G3****Compression Load Cell****Introduction**

Thank you for purchasing the TC-FSRSP(T)-G3 load cell. Please read this document completely before using this load cell to achieve its best performance and ensure safe and proper operation.

Included accessories

If anything is missing or damaged, contact the retailer where you purchased the product.

- Test report × 1
- Instructions for Use (this document) × 1
- Curved load button × 1
- Flat load button × 1

- Company names and product names in this document are the trademarks or registered trademarks of their respective owners.

IMPORTANT SAFETY INSTRUCTIONS**⚠ WARNING****If something abnormal occurs**

In the unlikely event that the product produces smoke, a strange smell or noise, for example, continuing to use it in this abnormal state could cause fire or electric shock. After cutting off the power, confirm that smoke is no longer being

produced. Then, request repair from the retailer where you purchased the product.

Do not open the cover.

Never remove the cover from this unit. Doing so could cause electric shock. Request inspection and repair from the retailer where you purchased the product. Do not alter this unit. Doing so could cause fire or electric shock.

Do not put foreign objects or water, for example, into the unit.

Do not place a container that holds water, for example, on top of this unit. Liquid overflowing or entering the unit could cause fire or electric shock.

Do not use the unit with any power supply voltage other than that specified.

Do not use the unit with any power supply voltage other than that specified. Doing so could cause fire or electric shock.

⚠ CAUTION**Unsuitable installation locations**

Do not place the unit in the following types of locations. Doing so could cause fire or electric shock.

- Locations where it might be exposed to smoke or steam, such as near a kitchen table or humidifier
- Unstable locations, including unsteady stands and tilted places
- Location that are very humid or dusty
- Locations that are exposed to direct sunlight

When not using the unit for a long time

For safety, cut the power supply when not using this unit for a long time.

Do not operate a damaged unit.**Precautions for use**

- This unit is not built to be water or splash resistant, and it cannot be used in conditions when the relative humidity is high. Moreover, use in atmospheres with corrosive gases should be avoided.
- Be careful to prevent water, oil and other substances from getting on the unit.

of the component attachment area.

Furthermore, since the attached part will sink by more than 30 μm when a load is applied, leave a sufficient gap between the part and the cover.

- Install this unit in a place where the structure is level and can sufficiently bear the load being used.
- Screw holes for attachment are located in four places.
- The screw hole dimensions are shown in the table below.

Model	Screw hole dimensions	Tightening torque
TC-FSRSP(T)-G3	M2.6 (3mm depth)	0.65 N·m

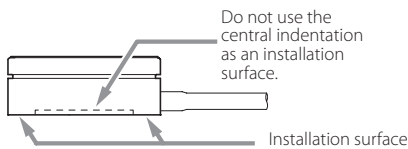
**Precautions when placing loads on the unit**

- Make sure the load is perpendicular to the surface to which this unit is attached.
- When using a flat load button, use it so that the load is equally distributed within a Ø7mm range.
- Apply the load so that it is centered on the center of the unit. If the load is not centered (eccentric load), twisting, for example, and measurement errors could occur. This could even result in damage.

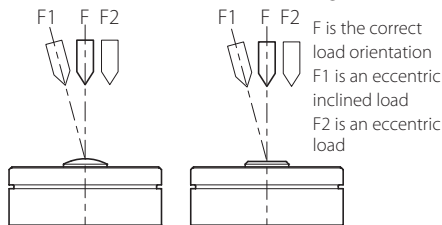
**Curved load button Flat load button**

- Be careful to avoid turning and twisting from lateral loads. This could cause troubles like those described in the previous item.

- Take extra care if the part that you have prepared is cylindrical. Even during installation, do not allow loads to be applied from the side or at an angle as shown in the illustration below. Doing so could cause the screw part to bend and damage internally.

Moreover, when securing the part, tighten with a torque of no more than 0.18 Nm or use a threadlocker and tighten gently by hand.

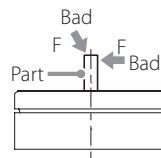

- A curved load button is used in load testing during production as shown in the illustration below, and the results are used in the TEDS data and the test report. Since the load point, load direction and other conditions differ when using a flat load button, differences in performance could occur compared to using a curved load button.

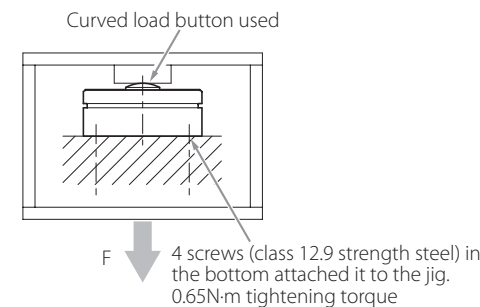

- Be careful to avoid applying loads that exceed the rated capacity. In particular, use caution when there are vibrations because loads that exceed the rated capacity

- Avoid use in conditions where condensation could occur.
- Connect cores to the load cell after discharging (eliminating) static electricity from your body.
- If the surrounding temperature changes suddenly, the values output by this device could become unstable, making accurate measurement impossible. (This could occur, for example, in a location blown by warm or cold air.)
- Conduct load calibrations periodically.

Installation procedures

To use this product, install one of the included load buttons (two types) or a part that you have prepared in the central M2 internal thread as shown in the illustration below.

- Tighten the included load button by hand to the position where the screw stops.
- Since it could loosen during use, we recommend coating the screw part with threadlocker. Doing so, however, will make removing the load button more difficult.

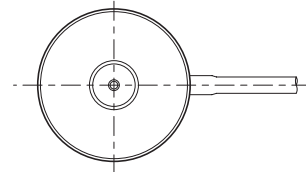
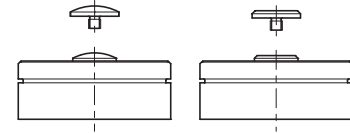
**Curved load button Flat load button**

- When attaching a part other than one of the included load buttons, make certain that it does not touch the cover. (Refer to the dimensional drawings.) Since the space between the cover and the attachment area of the loadbearing part is not always uniform, we recommend using a part that is smaller than the diameter

could occur due to sympathetic vibrations, for example.

- If the load receiving area (spherical surface) is contacted by something that is at a different temperature and the load is increased, the values output by this device could become unstable, making accurate measurement impossible.

In such a case, wait until the temperature difference ceases to exist before measuring.

Electrical connection of load cell with built-in TEDS

- Connect as shown in the illustration below. Incorrect connections could result in inability to balance and in errors occurring in the output voltage when loads are applied.

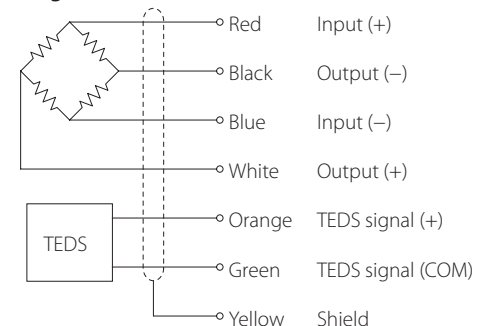
Using a cable with bare lead wires

- This unit has a built-in TEDS function.
- The orange and green cores in the cable and the F and G pins in the connector are wired for TEDS.
- This unit does not support remote sensing.
- Since products that support remote sensing use the same cables and connector pins as TEDS, be careful not to try mistakenly to use these pins for remote sensing.
- See the operation manuals of indicators and strain amps that support remote sensing for how to connect sensors with those units.

- The shield is not connected to the main body of this product. For this reason, if grounding is necessary because of external noise, for example, arrange to ground the shield to a part other than the body of this unit.
- If output values do not stabilize and are difficult to read due to external noise or other factors when connected to an indicator, use the filtering function of the indicator.
- Since the cable is directly connected to this unit, use a specialized cable to increase the length. (Please consult with us.)
- When conducting insulation resistance tests, limit them to the red, black, blue and white cores. Do not apply to the TEDS cores (orange and green).

Using a connector (optional)

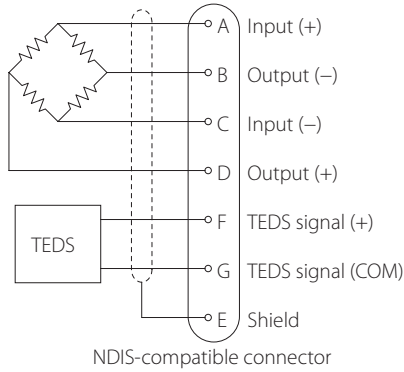

TEDS overview

TEDS (Transducer Electronic Data Sheet) is a memory chip that can electronically read and write sensor-specific data. The TEDS built into this unit has serial number, load cell rated output and manufacturer name data recorded on it. By connecting an indicator that supports TEDS, the TEDS data of the connected load cell will be automatically read and equivalent input calibration will be completed. (For details, read the operation manual of the connected indicator.)

Repeatability: 0.5% R.O.
 Zero balance: $\pm 30\%$ R.O.
 Safe excitation voltage: 5 V
 Input terminal resistance: $470 \Omega \pm 30\%$
 Output terminal resistance: $470 \Omega \pm 30\%$
 Insulation resistance: 1000 M Ω
 Compensated temperature range: 5 to 40°C (no condensation)
 Permissible temperature range: 0 to 50°C (no condensation)
 Temperature effect on zero balance: 2% R.O./10°C
 Temperature effect on output: 1% R.C./10°C
 Cable: $\varnothing 3$ mm 6-core robot cable

3m direct connection with bare lead wires
 Main component material: aluminum (stainless steel and iron components used inside)
 Environmental compliance: RoHS (10 substances)
 Other: built-in TEDS

Dimensional drawings

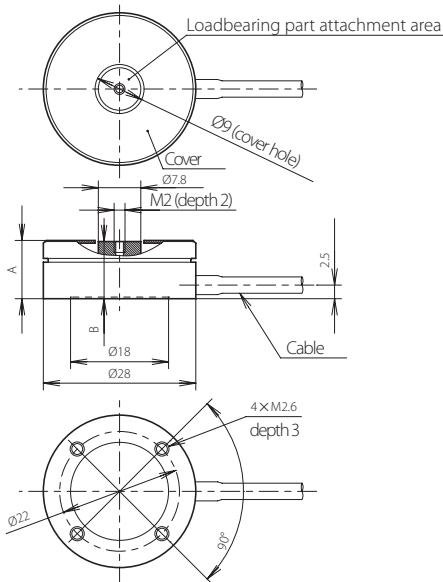

Refer to the connection diagrams in the "Electrical connection of load cell with built-in TEDS" section as well as the operation manual for the indicator being connected for procedures to make connections.

TEAC indicators that support TEDS include the TD-01 Portable, TD-700T, TD-260T, TD-275T and TD-280T. For details, inquire at a shop that handles these products.

If not using the TEDS function, do not connect the orange and green load cell cores.

Moreover, take measures to prevent the orange and green cores from touching other terminals.

Data recorded in TEDS are tested values from calibration conducted at room temperature during inspection before shipping from our company.

Load cell output will be affected by the environmental temperature where used, even when within the compensated temperature range established in the specifications. Although load cell output is calculated from the calibration value saved in TEDS, when the environmental temperature differs greatly from room temperature, the temperature impacts increase on the zero point and the output. For this reason, consideration of the effect on output voltage is necessary. Output voltage changes will be within the specification range as long as the unit is used at temperatures within the specification range.

When using the TEDS function

This product's cores for TEDS (orange and green) are protected by a plastic cover as shown in the illustration. This is to prevent miswiring and contact with other connectors during use, for example, which could cause shorting. To use the TEDS function, remove the tip of the plastic cover, following the perforations, from the end of the cables. Then, connect the TEDS cores (orange and green) to the indicator. Refer to the "Electrical connection of load cell with built-in TEDS" section for how to connect each wire.

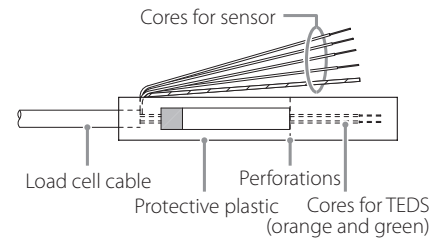

When not using the TEDS function

If not using the TEDS function, remove the entire protective plastic cover and cut off the TEDS cores (orange and green) around where the plastic cover was attached to the cable. If you use it without removing these cores, do not remove the protective plastic or make other arrangements to prevent the cores from touching other places.

Refer to the "Electrical connection of load cell with built-in TEDS" section for how to connect each wire.

Note about the tag attached to the TEDS cable

Since the protective plastic and tag are not suitable for the entire temperature range of this unit's specifications, do not expose them to high temperatures.

Handling after use

- When moving this unit while it is installed, take protective measures to prevent it from being shaken or subjected to excessive external forces.
- When storing it, keep it in a dry place where it will not be exposed to water or oil, for example.

Specifications

TC-FSRSP(T)-G3

Rated capacity: 10 N, 20 N, 50 N, 100 N
 Safe overload rating: 120% R.C.
 Rated output: 1 mV/V $\pm 50 \%$
 Linearity: 1% R.O.
 Hysteresis: 1% R.O.

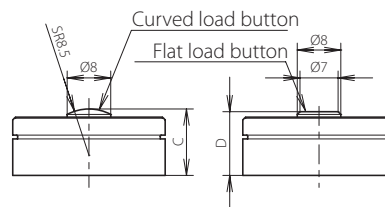

Rated capacity	A	B	C	D
10 N				
20 N	10.3	10.1	11.8	11.3
50 N				
100 N	10.7	10.5	12.2	11.7

Dimensions in millimeters (mm)

Warranty explanation

- The warranty period for this device is one year from the date of purchase.
- Be aware that repairs will require payment in the following cases even during the warranty period.
 - 1) Malfunction or damage due to misuse
 - 2) Malfunction or damage caused by modifications or repairs conducted by any party other than our company or a service person designated by our company
 - 3) Malfunction or damage caused by dropping, transportation or similar handling after product delivery
 - 4) Malfunction or damage caused by fire, earthquake, water, lightning or other natural disaster
 - 5) Malfunction or damage caused by external factors, including power supplies and equipment environmental conditions, that deviate from the operation requirements of this product
 - 6) Malfunction or damage if the product was not purchased from our company or an agent designated by our company
- We offer paid service after the conclusion of the warranty

period. For details, please contact the retailer where you purchased the unit.

- Be aware that our company will bear no responsibility for any secondary damages resulting from the operation of this device or related to data.
- Information is given about products in this manual only for the purpose of example and does not indicate any guarantees against infringements of third-party intellectual property rights and other rights related to them. TEAC Corporation will bear no responsibility for infringements on third-party intellectual property rights or their occurrence because of the use of these products.

Contact information

TEAC CORPORATION (Manufacturer)

147 Ochiai, Tama-shi, Tokyo 206-8530 Japan
 Phone: +81-042-356-9154

TEAC AMERICA, INC.

10410 Pioneer Blvd. Suite #1, Santa Fe Springs, California 90670, U.S.A.
 Phone: +1-323-726-0303

TEAC EUROPE GmbH. (EU Importer)

Bahnstrasse 12, 65205 Wiesbaden-Erbenheim, Germany
 Phone: +49-611-7158-349