

TD - 3 1 0 A
DIGITAL INDICATOR
OPERATIONAL MANUAL

TEAC INSTRUMENTS CORPORATION

AUG. 1994
REV. 1.00-00

TABLE OF CONTENTS

	PAGES
1) GENERAL	1.
2) FEATURE	1.
3) PREPARATION	2.
4) SAFETY MEASURES	3.
5) FUSE REPLACEMENT	4.
6) INSTALLATION	5.
7) DIMENTIONS	6.
8) CONNECTION GUIDE	7-11.
9) TRANSDUCER CONNECTION	12-15.
10) FUNCTIONAL DESCRIPTION	16-20.
11) KEY-SWITCH OPERATION	21-23.
12) CALIBRATION	24-28.
13) DIGITAL ZERO	29.
14) DIGITAL TARE SUBTRACTION	30.
15) DIGITAL FILTER & ZERO TRACKING	31-32.
16) LOCK BY KEY-SWITCH	33.
17) VOLTAGE OUTPUT (VOL.OUT)	34.
18) SI/F CONNECTION	35.
19) UPPER & LOWER LIMITS	36-37.
20) HYSTERESIS FUNCTION	38-39.
21) HOLD MODE (OP-2. TD-3102)	40-54.
22) BCD DATA OUTPUT (OP-3. TD-3103)	55-57.
23) RS-232C INTERFACE (OP-4. TD-3104)	58-64.
24) ANALOG CONDITIONER (OP-6. TD-3106)	65-67.
25) D/A CONVERTER (OP-7. TD-3107)	68-71.
26) MULTIPLE HIGH/LOW LIMIT COMPARISON	72-74.
27) SELF-CHECK	75-76.
28) BLOCK DIAGRAM	77.
29) SYSTEM DIAGRAM	78.
30) SPECIFICATIONS	79-82.

1) GENERAL

TD-310A DIGITAL INDICATOR is an advanced version of its previous model TD-310A which is a micro-computer based general purpose digital indicator for a strain gauge type transducer such as Load Cells. It is small in size but has a builtin key-switch panel designed for a various kinds of functional operations.

This Operation Manual for TD-310A provides you with the necessary information to prepare for its set-up and start-up and then to operate TD-310A properly so that you can enjoy its full benefits.

2) FEATURES

- 2-1. Easy and Simple Calibration by Key-Switch Operation.
- 2-2. Simple Presettings by Key-Switch Operation in Automatic Priority Order.
- 2-3. Non-Evaporating RAM (NOV RAM) Equiped. (No Need of Battery Back-up)
- 2-4. Low-Noise Preamplifier Equiped. (Well Stabilized Display)
- 2-5. High Speed Conversion. (15 Cycle per Second)
- 2-6. Serial Data Output Available for Large Sized Panel Display, Printer, Analog Converter (4 - 20mA, 0 - 10V), etc.
- 2-7. Wide Variety of Optional Units, such as Upper/Lower Limits Comparator, Peak-Hold, BCD Output, RS-232C Communication Interface, Analog Conditioner, and D/A Converter.
- 2-8. Excellent Noise-Resistivity by photocoupler for all Digital Input/Output including Serial Output and BCD Data Output.
- 2-9. Automatic Self-Check System for Internal Circuit Conditions.

3) PREPARATION





3-1. ANY DAMAGES DURING TRANSPORTATION ?

Right after being delivered to your hand, please unpack the shipping case and make sure if nothing has been damaged during its transportation.

3-2. CORRECT ITEMS DELIVERED ?

Packing List is attached to the shipping case. Please make sure if the delivered goods are right items that you ordered.

3-3. STANDARD ACCESSORIES ACCOMPANIED ?

- | | | | |
|-----------------------------------------------------|-----------------------------------------------------------------------------------|--------|-------------------------------------------------------------------------------------|
| 3-3-1. AC Power Cord |  | | 1 Unit |
| 3-3-2. Spare Fuse (0.5A) |  | | 1 Piece |
| 3-3-3. Mini-Screwdriver |  | | 1 Unit |
| 3-3-4. BCD Output Connector (when OP-3 ordered) ... | | 1 Unit |  |
| 3-3-5. Operation Manual for TD-310A | | 1 Copy | |

NOTICE

TD-310A is carefully manufactured and thoroughly inspected by our qualified engineers before its shipment from our factory. Therefore, its quality and function are fully guaranteed by us. However, in case of any damages or erroneous functions found, please immediately report to us such conditions directly or via our sales agent from whom you purchased.

When you return TD-310A to us for its repair, please pack it just in the same way and in the same box as it was delivered to you. If you no longer have the same box and packing materials, you are requested to pack it as follows.

- (1) First, TD-310A shall be wrapped with a strong wrapping paper or plastic sheet.
- (2) Please use a carton box of which size shall be about 10 cm larger than each corner of the housing size of TD-310A.
- (3) In the space between TD-310A and the carton box, some shock-absorbing materials shall be filled.
- (4) The carton box shall be sealed firmly with an adhesive tape and reinforced by a tape-band if necessary.

4) SAFETY MEASURES

Before starting operation of TD-310A , please pay your attention to the following points.

4-1. GROUNDING

To avoid such accidents as electric and electro-static shocks, it is highly recommended to connect both Terminal F (+S) and G (-S) located at the rear panel of TD-310A to the ground.

Terminal F and G are internally connected to Ground Terminal of Noise Filter of AC Power Input Unit and to the frame respectively.

Terminal 17 (SHLD) is for internal connection of a shielded part of Transducer Input Cable to the frame.

4-2. PROHIBITED AREAS FOR OPERATION

It is prohibited to operate TD-310A in the areas where any flammable gas or vapor is existing. If any questions on this subject, please ask us for further information concerned.

4-3. INPUT POWER SOURCE

TD-310A is run by AC Power (90-110V, 50/60Hz) and its maximum power consumption is 14VA. In case the power supply is not stable, a voltage stabilizer is to be connected to the main power line.

Upon request, the input voltage may be changed to another ratings.

4-4. OPERATION & STORAGE TEMPERATURE

Operation Temperature Range : -10 °C to +40°C

Storage Temperature Range : -40 °C to +80°C

5) FUSE REPLACEMENT

Fuse can be replaced by a new one as per following procedures.

- 5-1. Untighten the screws located at the rear panel and pull out the side rail as shown below.

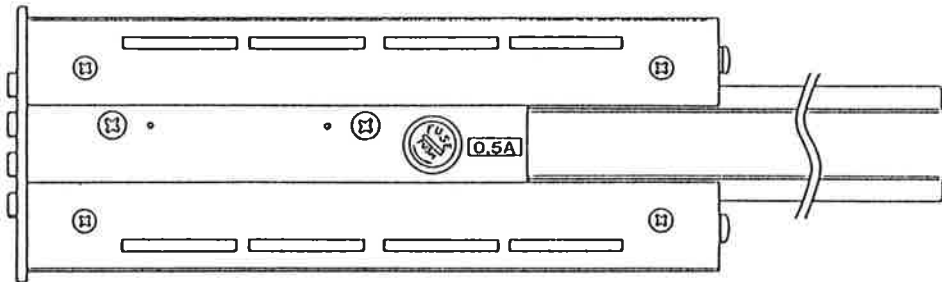

- 5-2. Push Fuse Holder and turn it counter-clockwise by the screw driver as far as it is to be moved out. Fuse rating is 0.5 A.

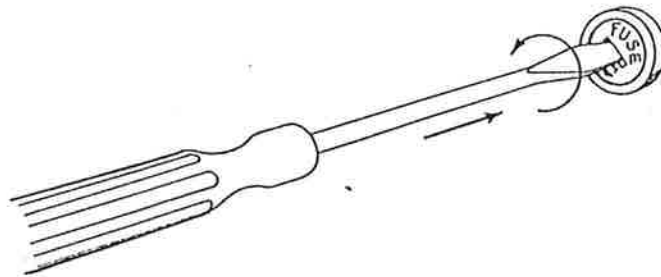

- 5-3. Replace with a new fuse and turn it clockwise into the fuse holder.

6) INSTALLATION

If TD-310A is installed in a panel rack, its panel cutting shall be made in accordance with the dimensions shown in 6-1 below, and then be fixed to the panel rack by the fixtures supplied with TD-310A.

- 6-1. Make a hole in the size, 136W X 68H (mm) in the panel rack as shown in the right.

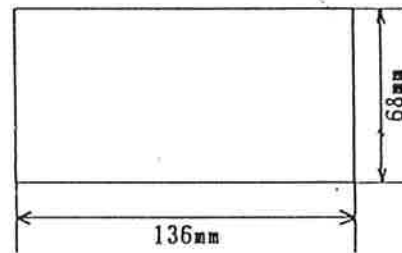

- 6-2. Remove the fastening bars at each side of TD-310A .
Then, insert TD-310A into the hole.

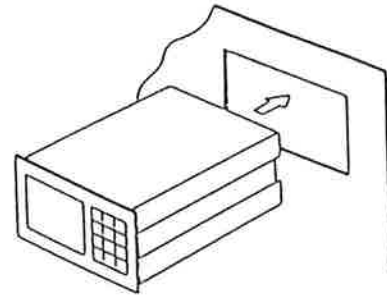

- 6-3. Put the fastening bars back to their original places from the rear side as shown in the right.

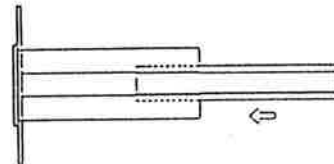

- 6-4. Fix the fastening bars firmly with the 4mm screws.

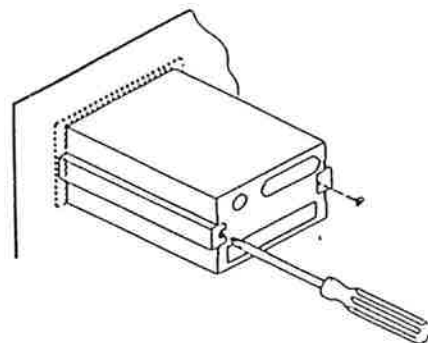

CAUTION

When it is necessary to be moved after installation, be careful any strong shocks or vibrations will not be given to TD-310A .

7) DIMENSIONS

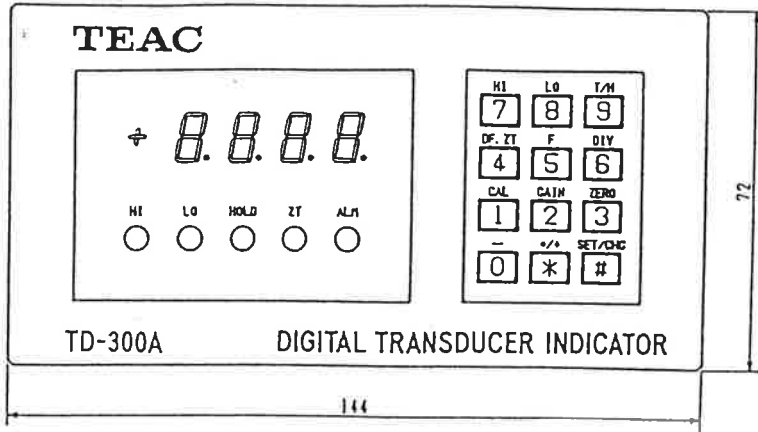

FRONT PANEL

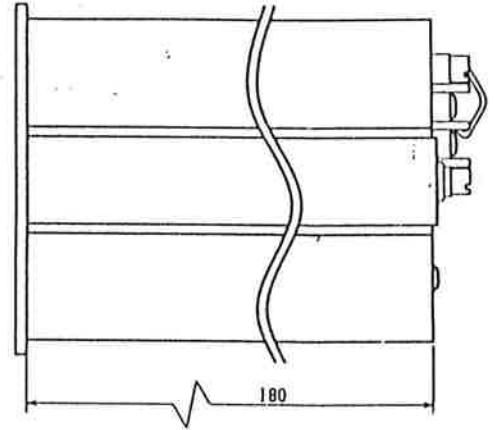

SIDE VIEW

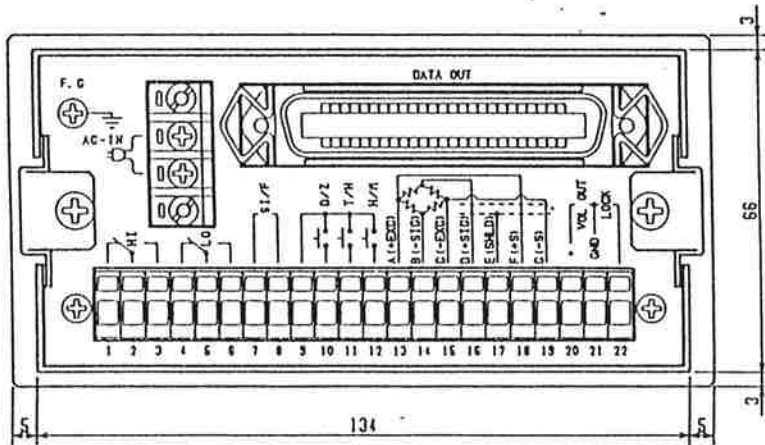

REAR PANEL

UNIT : mm

8) CONNECTION GUIDE (TERMINAL BOARD AT REAR PANEL)

Simple and easy Input/Output connection can be assured thanks to Cage Clamping System. (However, the cage clamping system is not applicable for BCD Output Terminals.)

8-1. The following are the cable connection procedures.

8-1-1. Remove the wire cover and take out about 5 - 6mm long bare wire as shown in the right.

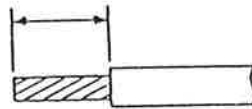

8-1-2. Reform or twist the bare wire so as to be easily inserted into the terminal hole.

8-1-3. Insert the screw-driver (supplied with TD-310A as Standard Accessory) into the upper hole and then lift it up.

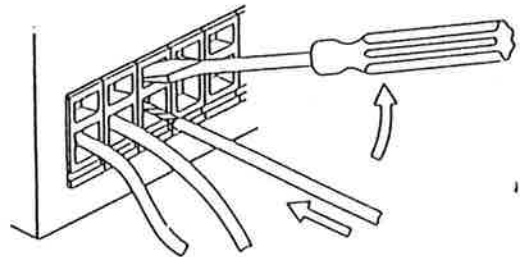

8-1-4. Insert the bare wire into the lower hole.

8-1-5. Pull the screw-driver out from the upper hole.

8-1-6. Make sure if the wire is clamped well and if it does not come out even when it is pulled out with a little force.

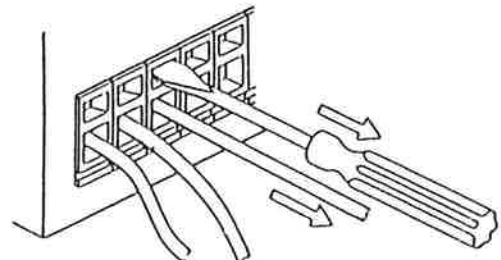

NOTICE

- (1) Diameters of connection cable shall be in the range of 0.2 to 2.5mm². (For the other wire sizes, some treatments are needed.)
- (2) If several wires are connected to one terminal hole, please twist those wires all together and then insert them into the lower hole.

8-2. INPUT MAIN POWER TERMINAL CONNECTION

8-2-1. PREPARATION FOR POWER CABLE

Before connecting the input main power line to the power terminals, arrange and fix a hole terminal (M3) at the end of line so that the connections are firmly made.

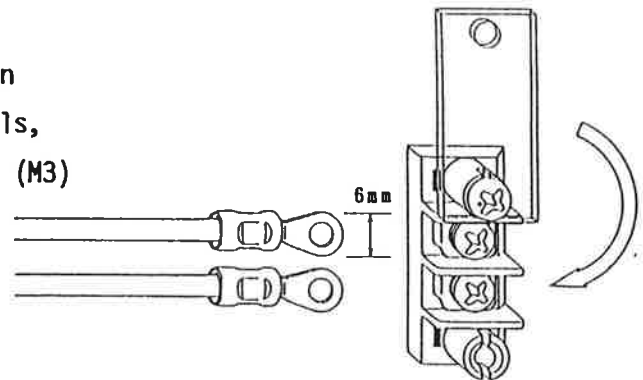

8-2-2. AC IN

Terminals for the input main power.

Standard Input Power Supply System is AC 90 - 110V, 50/60Hz.

Upon request, another voltage is also available.

8-3. F, G

Terminals for grounding.

A large wire (e.g. 0.75 mm²) is recommended for the ground cable.

8-4. { 1, 2, 3 } HI OUT

Terminals for Upper Limit Relay Output

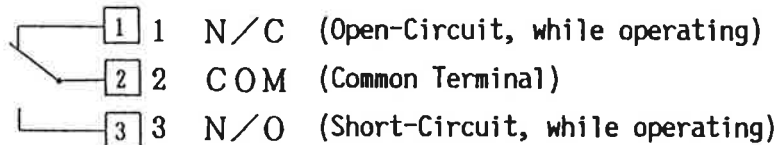

8-5. { 4, 5, 6 } LO OUT

Terminals for Lower Limit Relay Output

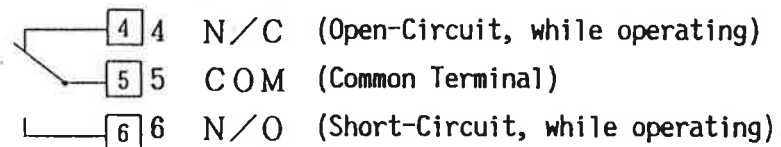

CAUTION

CAUTION TO UPPER AND LOWER LIMIT COMPARATIVE FUNCTIONS

- (1) Observe the resistive load ratings, AC 250V, 0.5A.
Avoid over-voltage or over-current which will cause damages of or will shorten the life of TD-310A .
- (2) Do Not make any Short-Circuits under loaded conditions.
Otherwise, TD-310A will get into troubles.
- (3) Make sure if the load side has Noise-Filters so that TD-310A can get reinforced against noises.
- (4) Shielded cable is not required.
Keep TD-310A away from the power lines or other wires on which noises are superposed.

EXTERNAL LOAD CONNECTION EXAMPLE OF UPPER AND LOWER LIMIT REPLAY

TD-310A SIDE ← → EXTERNAL LOAD

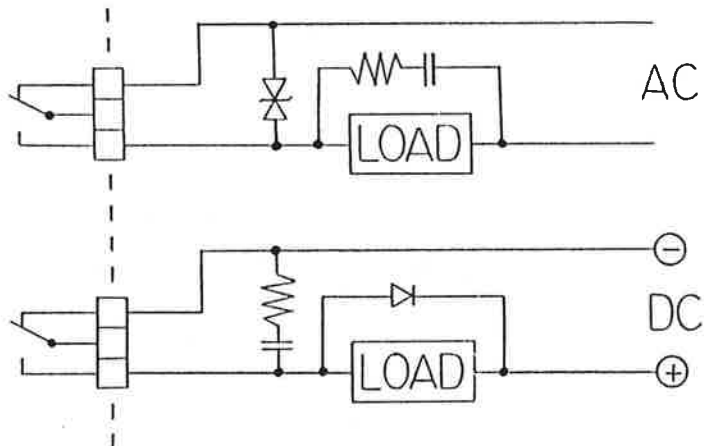

8-6. [7, 8] S I/F SERIAL OUTPUT

Terminal 7 and 8 are of Non-Polarity. External S I/F can be connected in parallel upto 3 units. Shielded Cables are not required, but the cables should be connected separately from AC lines and other lines with noises.

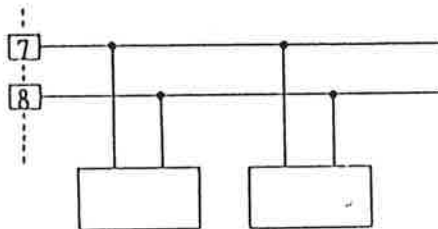

8-7. [9, 10, 11, 12] D/Z, T/H, H/M

(DIGITAL ZERO AND TRACK-HOLD COMMAND INPUT)

The connections are shown below. Terminal 9 is for Common.

Input can be made both for connecting points like Relay and Switch, and for non-connecting points like TTL Open Collector and Transistor.

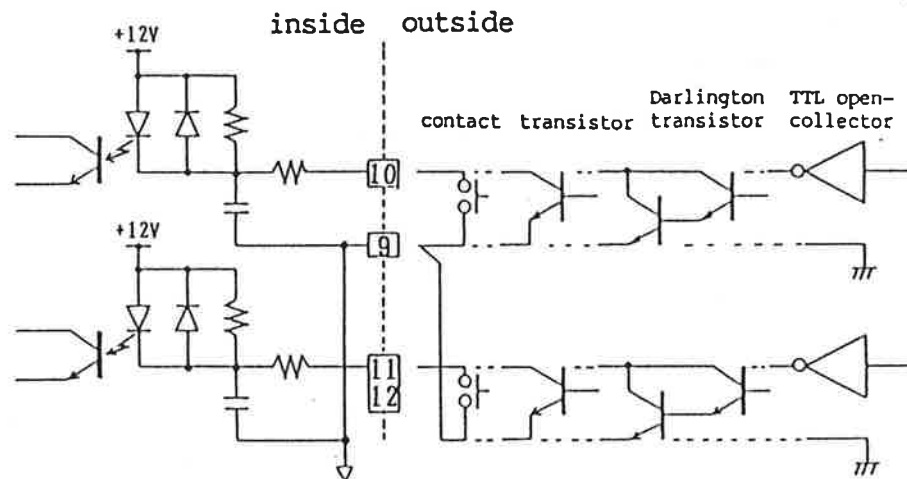

Shielded Cables are not required, but the cables should be connected separately from AC lines and other lines with noises.

CAUTION

CAUTION FOR D/Z, T/H, H/M EXTERNAL INPUT

- (1) External elements shall withstand 10 mA or more current flowing in circuits.
- (2) Current Leakage of external elements shall be within 100 μ A.
- (3) External elements shall be of 2V or less voltage when Terminal 9-10, 9-11 and 9-12 are in a short-circuit.

8-8. [13 ~ 19] TRANSDUCER INPUT

Upto the 4 units of 350 Ω Family Transducers can be connected in parallel with each other. For further details, please refer to SENSOR CONNECTION in "12".

8-9. [2 0, 2 1] VOL OUT

Voltage Output terminals.

Terminal 20 is for signal and

Terminal 21 is for common.

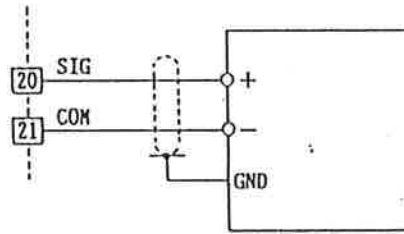

CAUTION

CAUTION TO VOLTAGE OUTPUT

(1) VOL OUT is not isolated from the internal circuits.

When connecting to an external equipment, the shielded cable should be used and its length should be within 2 or 3 meters.

If a longer cable is used, it might be influenced by noise.

(2) Do not have it short-circuited for a longer time than one hour.

Otherwise, it will cause troubles.

(3) Do not apply an external voltage to the Voltage Output Terminals.

Otherwise, it will break TD-310A .

8-10. [2 2] LOCK (CALIBRATION LOCKOUT)

This terminal is not for external interface. (Do not use it for external.)

Please refer to Calibration in "24"

9) TRANSDUCER CONNECTION

Excitation Voltage of TD-310A is DC 10V, or DC 5V, or DC 2.5V which can be selected. Connection can be made either for 4 wire or 6 wire System (Remote Sensing System). Upto 4 units of 350 Ω Family Transducers can be connected in parallel with each other. Here, "Remote Sensing System" means that even if a cable resistance get changed due to a longer cable and/or temperature variation by which a voltage exciting to the transducer becomes varied, the voltage value at the transducer is controlled and stabilized by this system.

9-1. CONNECTION PROCEDURE

9-1-1. SELECTION OF EXCITATION VOLTAGE

Check and see if the label on the case cover of TD-310A case cover shows the same excitation voltage as that of the transducer.

If it is different from the transducer's, change the excitation voltage of TD-310A by selection switch. However, when changing it, do not select a voltage exceeding the recommended value of the transducer.

NOTICE

MARKING CORRECTION OF EXCITATION VOLTAGE

In order to avoid any mis-connection, after selecting another excitation voltage, the voltage marked on the label must be corrected to the selected value like shown in the right.

EXCITATION VOLTAGE
(V) 10V 5V
 2.5V

If an excitation voltage of transducer is higher than the range of 10 ~ 12V, it is recommended to select 10V, while 6 ~ 7V, it would be 5V, and if it is 3V, it would be 2.5V.

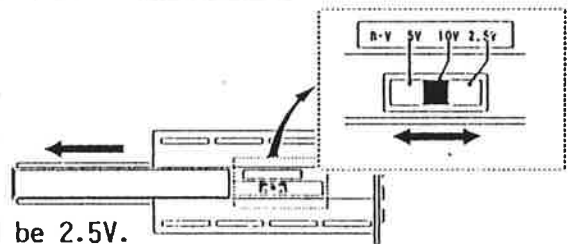

CAUTION

If a higher voltage is excited to the Transducer, it gets hot and drift becomes larger, and then, if it is kept on being excited by a higher voltage, the Transducer will get damaged.

9-1-2. TRANSDUCER CONNECTION

9-1-2-1. 4 WIRE CONNECTION SYSTEM

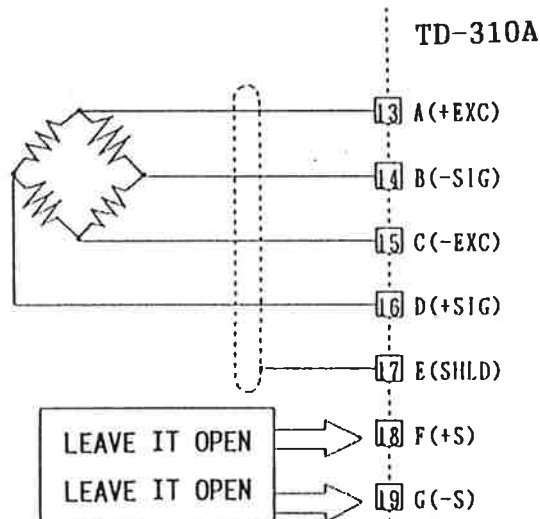

Terminal 18 (+S) and 13 (+EXC), and Terminal 19 (-S) and 15 (-EXC) are connected respectively in side of TD-310A . Therefore, just leave them open.

CAUTION

After it is used for 6 Wire System, it can be used for 4 Wire too. But, in this case, Terminal 18 (+S) and 13 (+EXC) as well as 19 (-S) and 15 (-EXC) should be connected together respectively. If those two Terminals are not connected, a high voltage (15V or more) will be supplied to the Transducer.

CAUTION

- (1) The connection shall be made with 4 Core Shielded Cable and be kept away from AC Lines and Lines with noises.
- (2) The Shielded Terminal no. 17 is to be connected with a thicker wire (e.g. 0.75mm Dia.) and be grounded.

9-1-2-2. 6 WIRE CONNECTION SYSTEM

TD-310A is set for the 4 Wire Connection when delivered from our factory. This means that Terminal 18 (+S) and 19 (-S) are connected to Terminal 13 (+EXC) and 15 (-EXC) respectively inside of TD-310A and, therefore, for the 6 Wire Connection, they must be disconnected. After having selected Excitation Voltage of Transducer, disconnect the 2 Jumper Wires on Printed Circuit Board as per the following.

- (1) Remove the bottom cover of TD-310A .

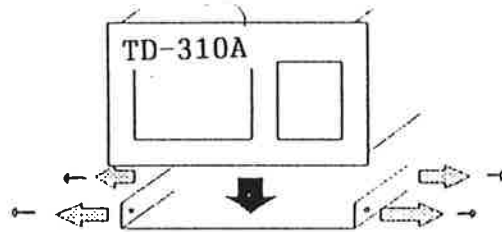

Take out the 4 screws at the bottom cover.

- (2) Cut off the 2 Jumper Wires on the PC-Board by nipper.

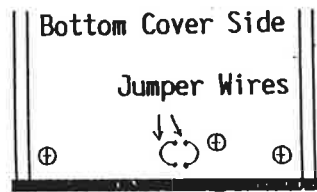

Terminal Board Side of Rear Panel

- (3) Put the bottom cover back to TD-310A , and then connect as follows.

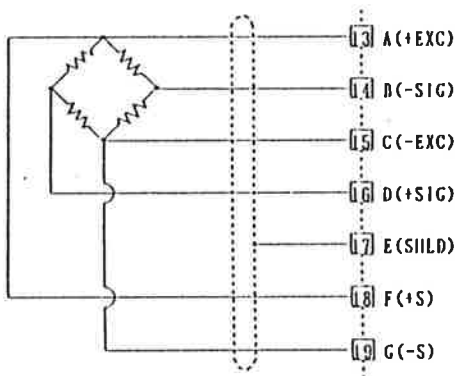

CAUTION

- (1) After having changed to the 6 Wire Connection System, if you use it as the 4 Wire Connection System again, the excitation voltage becomes over 15V regardless any selection of voltage.
- (2) Use a shielded 6 core cable and its wiring should be done separately from the lines with many noises and AC lines.
- (3) Use a thick wire like 0.75mm for Terminal 17 (Shielded) and ground it.

9-2. TRANSDUCER CABLES

Colors of Transducer Cables are subject to its manufacturer and also subject to the 4 Wire and 6 Wire Connection Systems.

Read thoroughly the operation manuals of transducer and then connect each cable properly. The following are some examples of the color coding.

9-3. RELAY CABLE

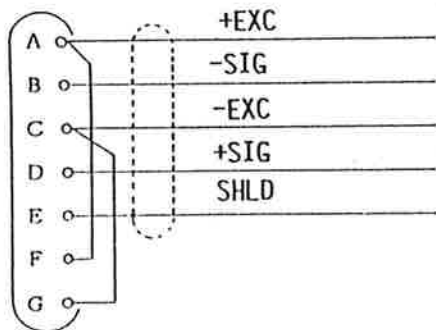

4 CORE CABLE

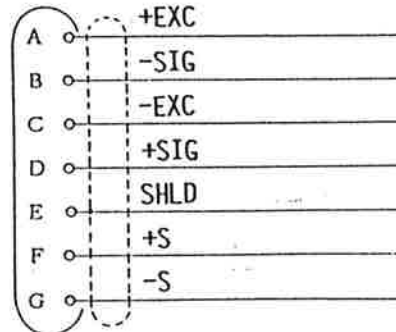

6 CORE CABLE

10) FUNCTIONAL DESCRIPTION

(FRONT PANEL)

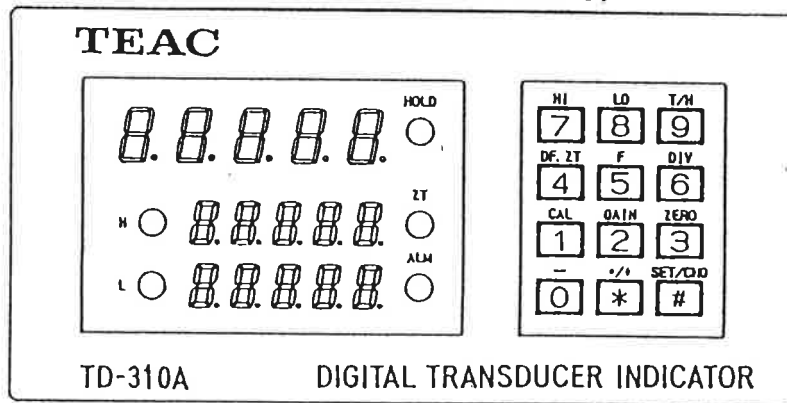

10-1. STATUS INDICATOR UNIT

These LEDs indicate the present conditions of TD-310A under a normal operation. During presetting, LEDs indicate the functions being preset. However, the following only describe under a normal operating conditions.

{HI}

ON, When an indicated value is higher than the upper limit preset value. If Upper/Lower Limit Comparator Option is equipped, Lighting shows the upper limit relay is driving.

{LO}

ON, when an indicated value is lower than the lower limit preset value. If Upper/Lower Limit Comparator Option is equipped, Lighting shows the lower limit relay is driving.

{HOLD}

ON, when an indicated value equals to the hold preset value. There are two kinds of Hold Functions (i.e. SAMPLE-HOLD and PEAK-POINT-HOLD. In both cases, an indicated value shows that it is at the same value as that of External T/H Signal or T/H Key Setting.

{ZT}

ON, when Zero Tracking is working.

{ALM}

ON, when it is under Over-Flow or another Abnormal Condition.

NOTICE

The following are Optional Functions.

(1) Peak-Hold Function	OP-2. TD-3102
(2) BCD Data Output	OP-3. TD-3103
(3) RS-232C Interface	OP-4. TD-3104
(4) Analog Conditioner	OP-6. TD-3106
(5) D/A Converter	OP-7. TD-3107
(6) Multiple High/Low Limit Comparative Functions	OP-8. TD-3108

10-2. DIGITAL DISPLAY UNIT

Indicated or various kinds of Preset values are to be displayed.

In a normal condition, a value corresponding to Transducer Output is displayed.

When a value is in over-flow, the following is to be displayed.

- FL1 (OVERFLOW 1 *①) : ADC - OVERFLOW
- FL2 (OVERFLOW 2 *①) : ADC + OVERFLOW
- FL4 (OVERFLOW 4 *②) : INDICATOR OVERFLOW (VALUE > 9999)

When presetting, a value corresponding to the preset value is to be displayed.

REMARKS :

- *① (OVERFLOW 1 & 2) is as Alarm Indication reporting some troubles of Misconnection and/or Breakage of Transducer, or Disconnection of Cable, or Over-load, or Inferior Contact, etc.
- *② (OVERFLOW 4) is for Alarm Indication reporting Missetting at the calibration.

10-3. PRESETTING UNIT

This is Key-Switch Panel for Calibration, Upper/Lower Limit, and other Presettings. Each Key-Switch has a function as follows.

- 0 ... Minus or Figure 0 Input
- * ... Decimal Point, Plus and Cancel of Presetting
- # ... Command to start Presetting Input or to register Preset Value
- 1 ... Equivalent Input Calibration or Figure 1
- 2 ... Actual Load Calibration or Figure 2
- 3 ... Digital Zero or Figure 3
- 4 ... Selection of Digital Filter or Zero Tracking, or Figure 4
- 5 ... Digital Tare Subtraction and Figure 5
- 6 ... Minimum Scale Designation or Figure 6
- 7 ... Upper Limit Presetting or Figure 7
- 8 ... Lower Limit Presetting or Figure 8
- 9 ... Hold Mode Selection or Hold Command, or Figure 9

(REAR PANEL)

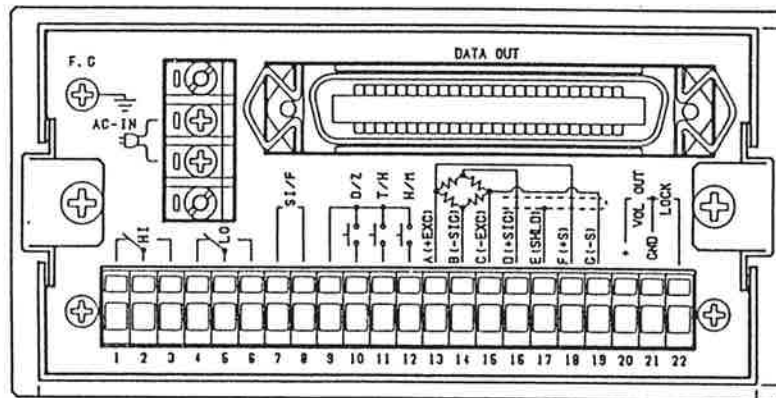

10-4. CONNECTION TERMINAL BOARD

AC IN

Input Power Supply Terminal. Standard is for AC 100V.

Upon request, Input Voltage can be modified.

F. G

Ground Terminal. To protect from any damages of electric or electrostatic shocks, this terminal should be grounded.

{1 · 2 · 3} HI OUT

Upper Limit Relay Contact Output Terminals

{4 · 5 · 6} LO OUT

Lower Limit Replay Contact Output Terminals

NOTICE

PRECAUTION OF UPPER/LOWER LIMIT COMPARATIVE FUNCTIONS

(1) Utilize within its ratings (AC 250V, 0.5A at Resistance Loaded condition).

Avoid any Over-Voltage or Over-Current. Otherwise, its life will be shortened and, at the same, it will cause some troubles.

(2) Avoid any short-circuits under loaded conditions.

Otherwise, it will be broken.

(3) Connect a Noise-Killer to the load so that it can withstand against noises better.

[7 · 8] S I/F

Serial Data Output Terminals for External Display or Printer, etc.

[9 · 10] D/Z

Digital Zero Input Command. Digital Zero works when switching from Open to Short-Circuit. This will not be effective when Terminal 21 and 22 are in the open condition (Calibration Enable).

[9 · 11 · 12] T/H, H/M

Hold Input Command. There are the 4 hold modes.

For further detail, please refer to "HOLD MODE OPERATION".

[13~19] TRANSDUCER INPUT

Upto The 4 units of Transducer (350 Ohm Family) can be connected in parallel.

[20 · 21] VOL OUT

Analog Output (Voltage Output in proportion to Transducer Input).

Output Voltage Level is about 2V per 1mV/V Input (e.g. about 1V Output at 0.5mV/V Input about 6.4V Output at 3.2mV/V Input).

[21 22] LOCK

Input Terminal to lock out Calibration Operation. When Terminal 21 and 22 are in short-circuit, Calibration is prohibited.

When Terminal 21 and 22 are open, Calibration can be carried out.

After Calibration is over, Terminal 21 and 22 must be short-circuited so as to protect from any mis-operations.

10-5. FUSE

This is Power Fuse (0.5A) for AC IN. Fuse is located at the left hand side when viewed from Rear Panel.

For the change of Fuse, please refer to "HOW TO CHANGE OF FUSE".

10-6. DATA OUT (SPACE FOR OPTIONS)

One of the following Optional Functions can be connected here.

For further detail, please refer to the respective pages.

- | | |
|------------------------------------|-----------------------|
| (1) BCD Data Out (OP-3) | Refer to the page 55 |
| (2) RS-232C Interface (OP-4) | Refer to the pages 58 |
| (3) Analog Conditioner(OP-6) | Refer to the pages 65 |
| (4) D/A Convertor (OP-7) | Refer to the pages 68 |
| (5) Multiple High/Low Limit (OP-8) | Refer to the pages 73 |

1 1) KEY-SWITCH OPERATION

● KEY-SWITCH OPERATION BASED ON OBJECT PRIORITY ORDER

Key-Switch has two different operation functions (i.e. Presetting Subject and Figure Input) and is operated in Automatic Priority Order.

11-1. TEN-KEY AS SELECTION SWITCHES

Presetting Subjects can be selected by Ten-Key. Selections can be repeated and revised as many times as necessary. Once # Key is pushed, the selection is finalized and the function is commanded or the pre-setting is registered.

11-2. PRESETTING DATA DISPLAY

If a presetting subject is selected, its preset data are shown in the display panel. At the same time, [H I] LED is flashing to indicate the condition. [L O], [H O L D], [Z T] and [A L M] are shown in the page .

11-3. PRESETTING TO BE STARTED BY # KEY

Push # Key so that you can input a figure as a selecting subject. [H I] LED is changed from flashing to lighting, and MSD (Most Significant Digit) of a displayed figure is flashing.

11-4. TEN-KEY AS FIGURE INPUT SWITCHES

TEN-KEY is turned from Function Keys to Figure Keys. A flashing point is the place where you can input a figure. When a figure is input, a flashing point is shifted to its next digit (i.e. the second largest digit).

If LSD (Least Significant Digit) is input, the largest digit starts flashing again. If wanted, a new figure can be input again for correction.

11-5. REGISTRATION BY # KEY

If a displayed figure is correct and corresponds to your aiming subject, its registration can be made by pushing the # Key regardless a flashing point. Now, a transducer input is to be displayed.

If a new registration is required, start again selecting a presetting of subject.

NOTICE

- (1) Presetting Unit is based on First Priority Object System and therefore, + Key, - Key, Decimal Point, etc. become effective only when it is in order.
- (2) Only when a registration of Upper/Lower Limit Presettings is input, Minus by 0 Key and Plus by * Key become effective.
- (3) Key becomes Decimal Point Function Key only while registering figure for Simulative Calibration and for Real Loaded Calibration. In the other cases, Decimal Point is automatically determined and displayed.

● SUBJECT SELECTION DISPLAY

CONDITION DISPLAY L E D					SELECTION KEY	PRESETTING SUBJECT
HI	LO	HOLD	ZT	ALM		
	○	○	○	○		Self-Check
	○	○	○	●		Transducer Output Registration for Equivalent Input Calibration
	○	○	●	○		Indicated Figure Registration for Calibration
	○	○	●	●		Zero Point and Zero Auto Registration while Calibration
	○	●	○	○		Selection of Digital Filter · Zero Tracking
	○	●	○	●		Digital Tare Subtraction
	○	●	●	○		Minimum Scale Presetting
	○	●	●	●		Upper Limit Presetting
	●	○	○	○		Lower Limit Presetting
	●	○	○	●		Hold Mode Section

○ ····· LED OFF
 ● ····· LED ON
 ····· LED 00 or FLASHING

CAUTION

- (1) Please do not leave more than 12 seconds between the TEN-KEY Inputs.
- (2) If it passes more than 12 seconds, it returns to Transducer Value Display Mode automatically.
- (3) In this case, all input data are cleared and you must start from the beginning again.

1 2) CALIBRATION

12-1. EQUIVALENT INPUT CALIBRATION

What is Equivalent Input Calibration ? Calibration can be done just by registering a rated output of transducer, but not by input of an actual load.

For Example :

Heavy Weight Measurement : 2.001 mV/V - 100.0 kgf
 Pressure Measurement : 2.002 mV/V - 10.00 kgf/ cm²
 Torque Measurement : 2.502 mV/V - 15.00 kgf · m

By registering the above values, Gain will be automatically adjusted and fixed.

12-2. EQUIVALENT INPUT CALIBRATION PROCEDURE

12-2-1. Release LOCK (Terminal 21 and 22) located at the rear panel.

Make Terminal 21 and 22 (LOCK) open.

If LOCK is made by KEY-SWITCH, release it as follows.



NOTICE

LOCK by Terminal Board and LOCK by KEY-SWITCH are both for the LOCK Function (Double Function). If LOCK is made by the both, you have to release the both LOCKs.

For KEY-SWITCH LOCK, please refer to KEY-SWITCH LOCK FUNCTION in the page 33.

12-2-2. Register the minimum figure for digital value changes (i.e. select a figure among 1 to 100). When TD-310A is delivered to you, 001 was registered for this purpose. If necessary, this registration can be done as follows.

Registration can be repeated after Input of LSD (Least Significant Digit) is finished.

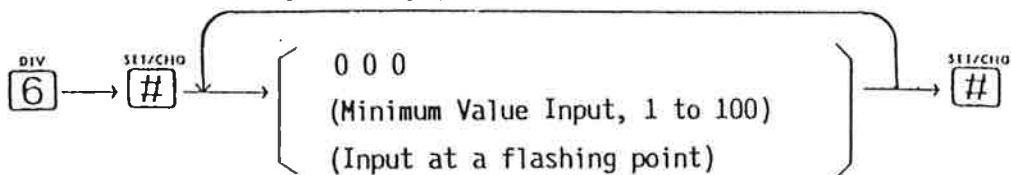

12-2-3. Register Transducer Rated Output

Registration can be repeated again from MSD (Most Significant Digit) after Input of LSD (Least Significant Digit) is finished.

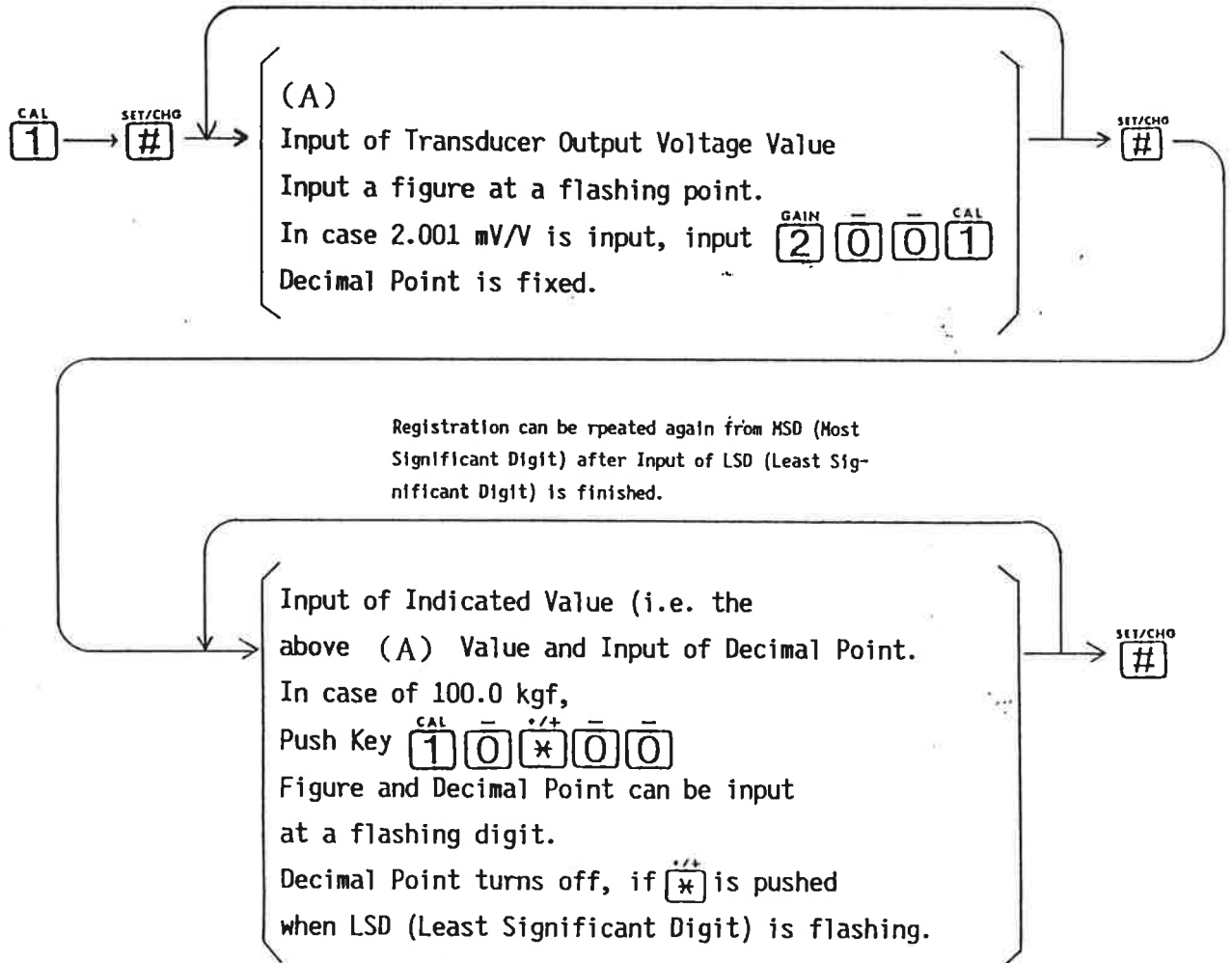

Decimal Point is inserted at the right side of the flashing digit.
Input Decimal Point ($\overset{+/+}{\boxed{*}}$) and then, input a figure at the flashing digit.

12-2-4. Register Zero Point under Non-Loaded (Input Zero) Condition

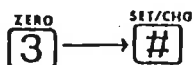

NOTICE

Zero Point Data registered here are Initial Zero Point Data, but not "DIGITAL ZERO" under a normal operation.

12-2-5. Prohibit Calibration Setting (LOCK)

Connect Terminal 21 and 22 at the rear panel together (i.e. Short-Circuited). Every time when a calibration is over, Terminal 21 and 22 must be connected so as to protect from any mis-operations.

NOTICE

Calibration Value and Zero Point Data are recorded in NOV RAM (Non-Evaporating RAM). Even when Power-Failure, the data will not be extinguished.

12-3. ACTUAL LOAD CALIBRATION

What is Actual Load Calibration ?

When a transducer is loaded actually, its indicated value is converted to a certine figure, which is called as Actual Load Calibration.

12-4. ACTUAL LOAD CALIBRATION PROCEDURE

12-4-1. Release LOCK by disconnecting Terminal 21 and 22 at the rear panel. (Terminal 21 and 22 are open now.)

If LOCK is made by KEY-SWITCH, release it as follows.



NOTICE

LOCK by Terminal Board and LOCK by KEY-SWITCH are both for LOCK Function (Double Function). If LOCK is made by the both, you have to release the both LOCKs.

For KEY-SWITCH LOCK, please refer to KEY-SWITCH LOCK FUNCTION in the page 33.

12-4-2. Register Minimum Stepping Value.

Select a value between 1 to 100 as Minimum Stepping Value.

When delivered from our factory, 001 is registered already. If you use this value, you do not have to register it again.

The following is the registration procedure.

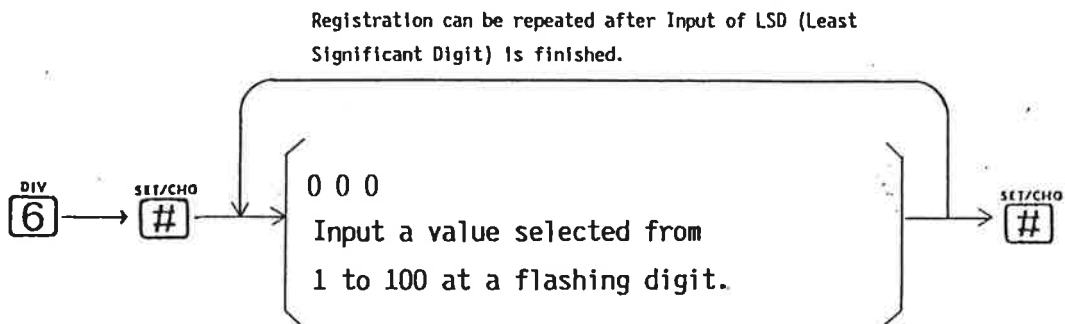

12-4-3. Register Zero Point under Non-Loaded (Input Zero) Condition.

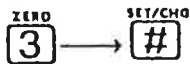

NOTICE

Zero Point Data registered here are Initial Zero Point Data, not Digital Zero under a normal operation.

12-4-4. Register Indicated Value under Actual Load Condition.

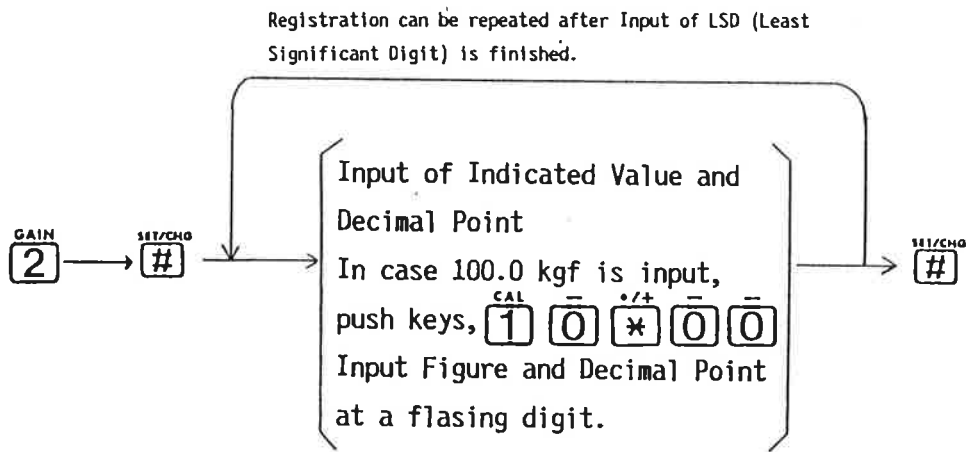

Decimal Point is inserted at the right side of the flashing point.
Input Decimal Point (^{*/+}*) and then, input a figure at the flashing digit.

12-4-5. Set LOCK

Connect Terminal 21 and 22 in the rear panel together. To protect from mis-operations, be sure to make these two terminals short-circuited every time when Calibration is over.

NOTICE

Calibration Value and Zero Point Data are recorded in NOV RAM (Non-Evaporating RAM) so that such data can not be extinguished even in cases of power-failures.

13) DIGITAL ZERO

13-1. What is Digital Zero ?

It is to make a displayed value Zero.

13-2. DIGITAL ZERO OPERATION

13-2-1. Digital Zero by Key-Switch

Push Key, 3^{ZERO} → #^{SET/CHO}

Now, Digital Zero Circuit is working and Displayed Value is forced to Zero.

13-2-2. Digital Zero by External Signal (D/Z Input Signal)

Right after making Terminal 10 (D/Z) and 9 short-circuited, Digital Zero starts working and a displayed value is forced to Zero.

Input can be made either by contact point (Relay, Switch) or by Semiconductor Switch (TTL, Transistor).

EXAMPLE OF EQUIVALENT INPUT CALIBRATION INPUT CIRCUITS AND EXTERNAL ACTIVE CIRCUITS.

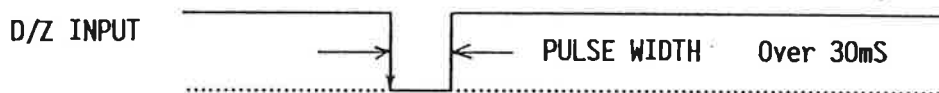
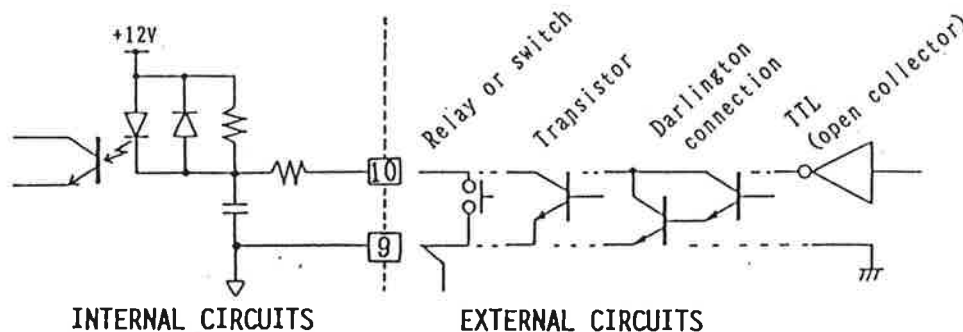

CAUTION

- (1) Digital Zero does not work during Calibration Mode (i.e. Terminal 21 and 22 (LOCK) are in open-circuit.
- (2) When power-failure, Digital Zero is released. Set it again, if necessary.
- (3) Voltage Output can not be forced to Zero by Digital Zero. However, if Voltage Output Option (OP-7) is equipped, by Digital Zero Voltage Output can be forced to be Zero.

14) DIGITAL TARE SUBTRACTION

14-1. What is DIGITAL TARE SUBTRACTION FUNCTION ?

A previously known Tare Weight can be subtracted from the displayed value and make only Net Weight Value displayed by this function.

If a gross weight is loaded, you can subtract the tare weight from the displayed value just by input the known tare value.

Also if Zero Calibration is not possible, you can adjust the zero point by input of an appropriate value.

NOTICE

- (1) If a setting value is with "-" (Minus Sign), it will be added to the displayed value.
- (2) In case that the displayed value is needed to be changed to an aiming value, but it can not be done by calculated tare subtraction, Zero is input for Digital Tare Subtraction and then, again calculate a tare value and input it so as to get the aimed value.

14-2. DIGITAL TARE SUBTRACTION PROCEDURE

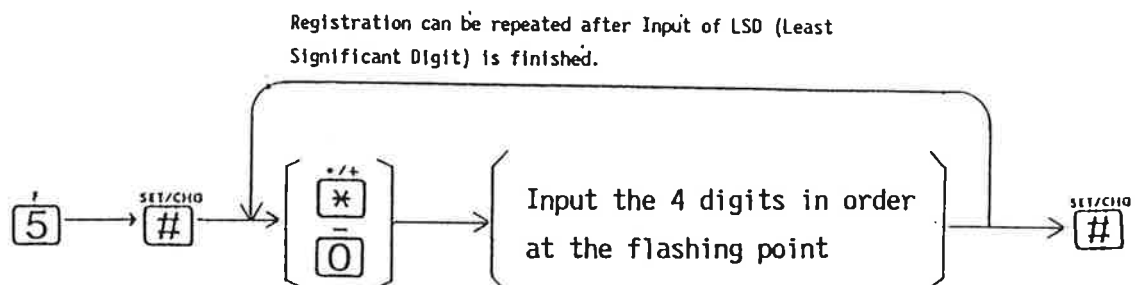

NOTICE

Digital Tare Subtraction Input Value is recorded in NOV RAM (Non-Evaporating RAM) so that the data will not be extinguished even in cases of power-failures.

15) DIGITAL FILTERING & ZERO TRACKING

15-1. What is Digital Filter ?

It is to make Input Transducer Signal averaged so as to get Displayed Value stabilized.

15-2. TD-310A has the builtin Shifting and Averaging Type Digital Filter.

When displayed values are unstable due to mechanical vibrating components being superposed on Transducer Signals, Filtering power can be selected according to Input Signal Conditions, which is effective.

15-3. What is Zero Tracking ?

It is to compensate automatically a fine Zero Point Shift. Zero Tracking is effective to minimize measuring errors caused by Zero Point Shift of Transducer, TD-310A and a small amount of material being measured. The following is Automatic Compensation System.

A small amount of Zero Point Shift in a limited time is automatically ignored and considered as Zero. Time Component (Delay) and Amount of Changes (Band) can be selected in several combinations.

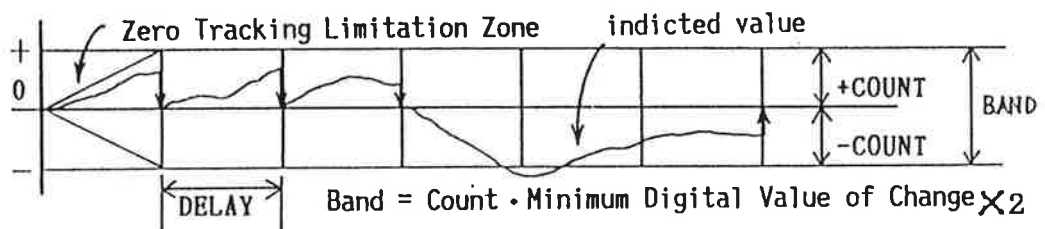

15-4. SELECTION OF DIGITAL FILTER AND ZERO TRACKING

Registration can be repeated after Input of LSD (Least Significant Digit) is finished.

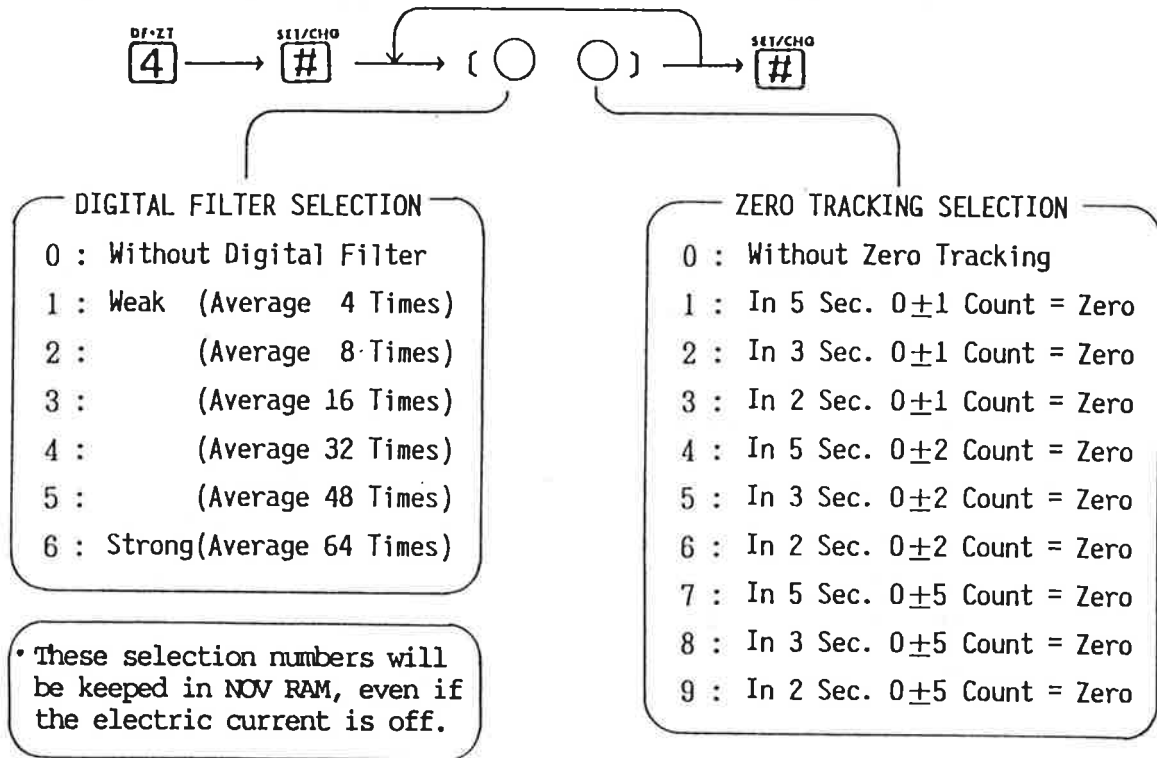

15-5. RELATION BETWEEN DIGITAL ZERO AND TRACKING ZERO

Zero Tracking starts working at a point where Digital Zero was set.

For example, let's say 0025 is an indicted value and Zero Tracking Selection 5 (± 2 Count/ 3 Sec.) was selected. ± 1 Count Drift per 3 Seconds does not make Zero Tracking run. But if 0025 was forced to be 0000 by Digital Zero Function and then after, ± 2 Count Drift in 3 Seconds makes Zero Tracking run and the displayed figure is kept in 0000.

16) LOCK BY KEY-SWITCH

Calibration Value and Preset Value can be protected from mis-operation by Key-Switch.

16-1. CALIBRATION LOCK

There are two ways to have LOCK Functions (i.e. one by connecting Terminal 21 and 22 (LOCK) at the rear panel, and the other by Key-Switch).

Setting steps of Key-Switch LOCK are as follows.

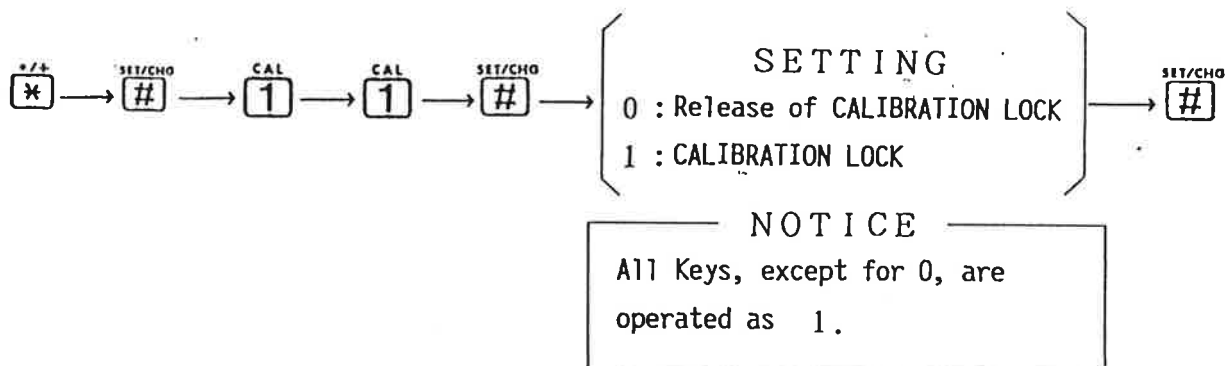

CAUTION

Each LOCK (i.e. by Terminal Connection and by Key-Switch) is independent. Therefore, while calibrating, the both LOCKs should be released respectively.

16-2. SETTING LOCK

All setting data can be protected from mis-operation by Key-Switch.

After SETTING LOCK is done by Key-Switch, it will start setting operation even entering setting values. (Setting Values can be displayed, but not be registered even pushing ^{SET/CHO} # Key.)

Therefore, for registering Setting Values, you have to release SETTING LOCK as follows.

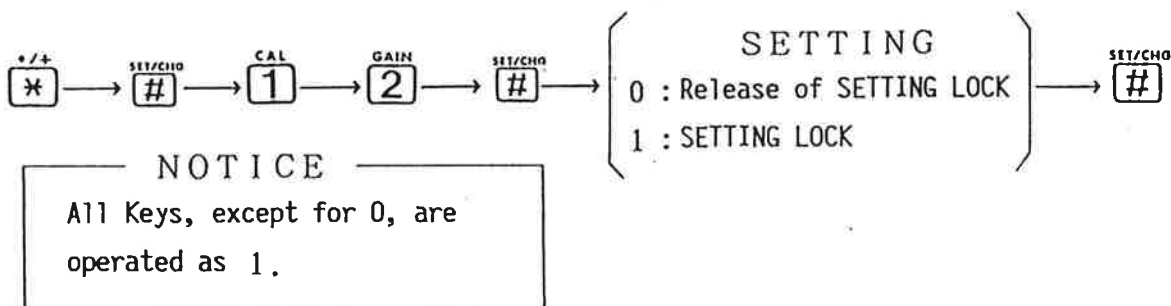

17) VOLTAGE OUTPUT (VOL. OUT)

17-1. Voltage Output (VOL. OUT) is a sort of the interface to get Analog Voltage in proportion to Transducer Input. This interface is suitable to observe and record Wave-Form by recorder. Output Level is about 2V per Input of 1mV/V.

17-2. EXAMPLE OF CONNECTION BETWEEN INTERNAL OUTPUT CIRCUIT AND EXTERNAL UNITS

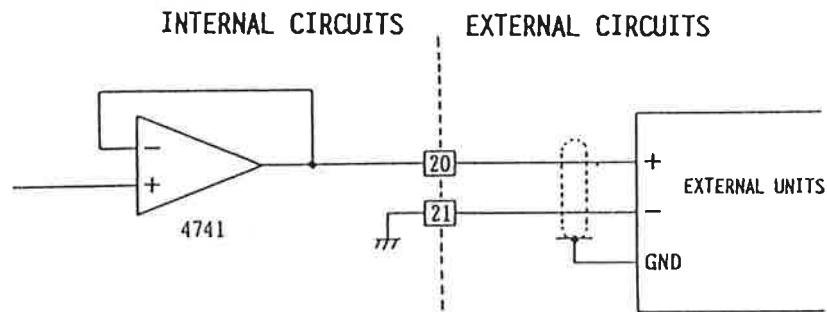

VOLTAGE OUTPUT SIGNAL

- Output Signal is taken from the prior stage where Transducer Signal Input is to be converted to A/D.
Therefore, Output Signal is in proportion to Indicated value, but not the indicated value itself.
Due to this reason, Output Signal does not coincide Digital Zero, Auto-Gain and other digitally treated values.
- Response Frequency of Output Signal is DC upto about 1 kHz/-3dB.
- Output Level is about 6.4V at Maximum Input 3.2mV/V.
Linearity is kept in linear upto Input 5mV/V and Output 10V.
However, digitally 3.2mV/V would be maximum.
- With Peak-Hold Option, Peak-Hold Value in Analog is to be output.
But in this case, there is a Doloop about 0.05%/FS per 1 second.

18) S I/F CONNECTION

- 18-1. S I/F (Original Designed Serial Interface) is specially designed to connect easily TD-310A to Peripheral Equipments (e.g. Printer, Display, Presetting Unit) of F Series. Just connect Terminal 7 and 8 (SI/F) to SI/F Terminals of an external equipment. There is no polarity in this connection.

SI/F (2 Core System)

Transmission System : Start-Stop, Synchronous

Transmission Distance : Upto Approx. 300 meters

Transmission Speed : 600bps

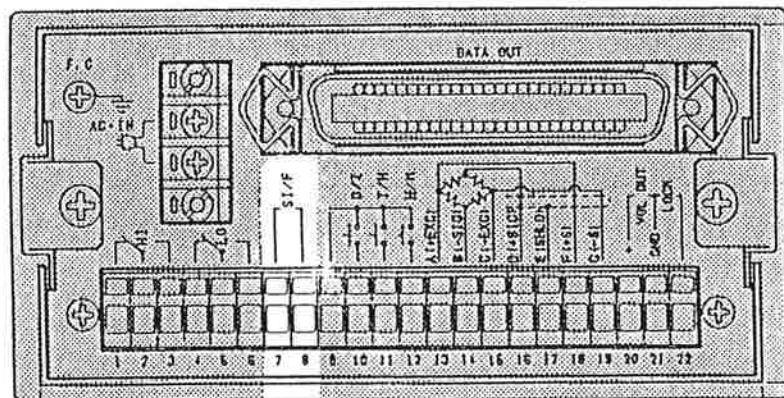

Parallel Connection upto 3 Units

(If more than 4 unit connection needed, consult with us.)

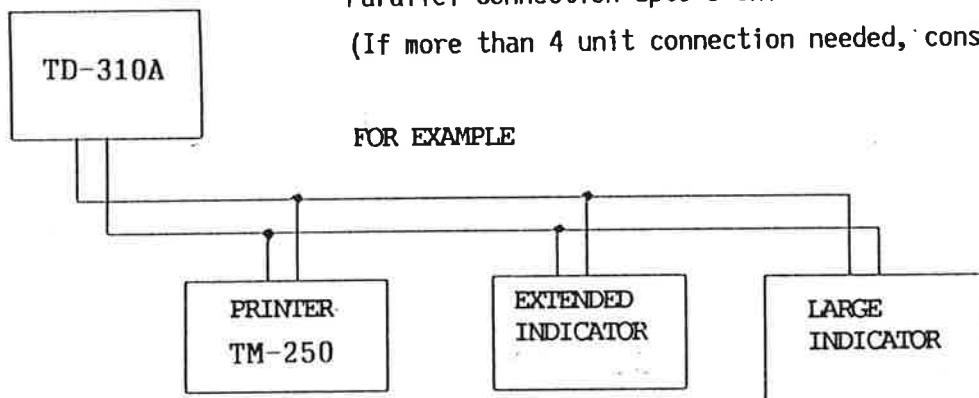

18-2. NOTE FOR CONNECTION

The connection cable can be of two cores in parallel.

However, when wiring, the cable must not be placed in parallel to AC Lines and/or High Voltage Lines.

Connection to Cage Clamp System Terminal Board is to be referred to 8) CONNECTION GUIDE.

19) UPPER & LOWER LIMITS

19-1. What is Upper & Lower Limit Comparator ?

It is to operate Upper or Lower Limit Relay when an indicated value exceeding the preset Upper or Lower Limit Value, and the relay operation is shown by LED lighting in the front panel.

19-2. UPPER & LOWER LIMIT RELAY OPERATION TIME CHART

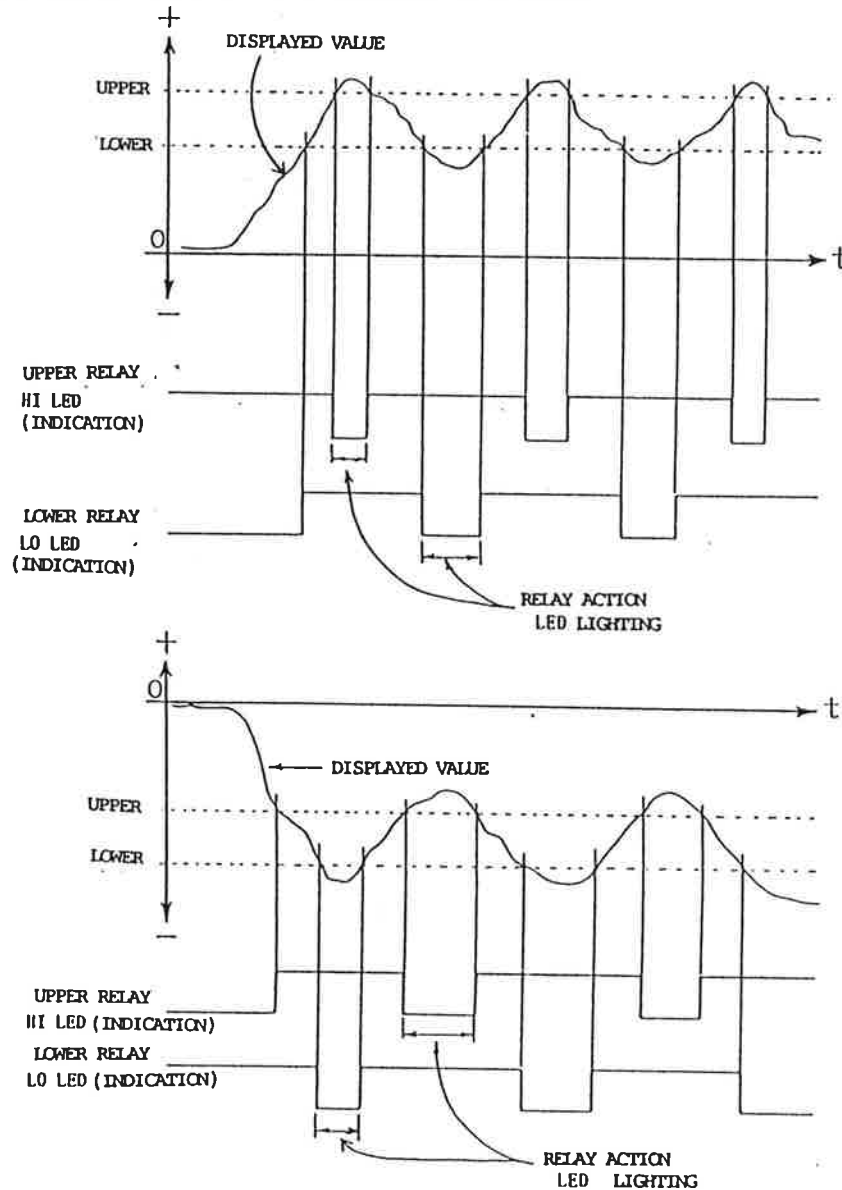

NOTICE

Upper Limit Relay and HI LED turn on :

when Indicated Value $>$ Upper Limit Preset Value.

Lower Limit Relay and LO LED turn on :

when Indicated Value $<$ Lower Limit Preset Value.

Comparing Calculations are based on Arithmetic Comparison taking into account of Symbols as well.

19-3. UPPER & LOWER LIMIT VALUE REGISTRATION

19-3-1. Upper Limit Value is registered as follows.

(Registration can be done by RS-232C (OP-4). Refer to Page 58.)

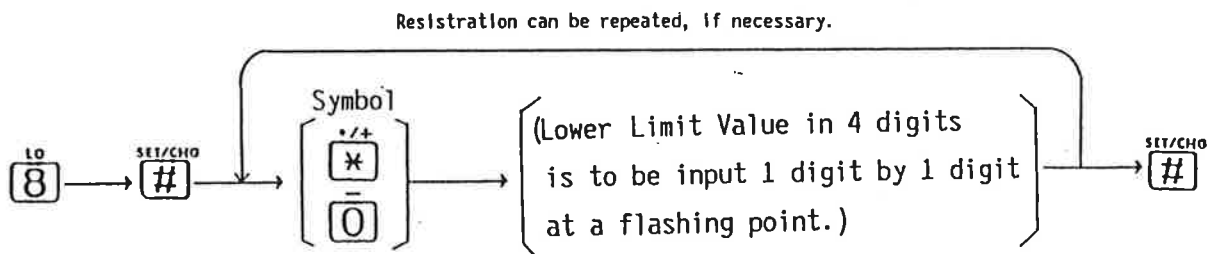
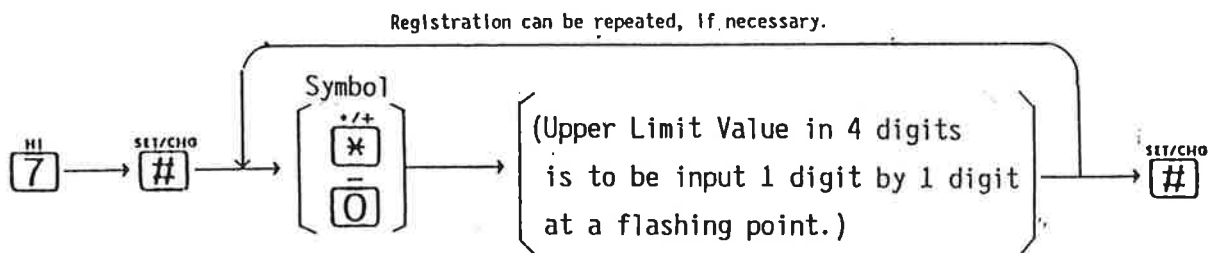

NOTICE

Both Upper & Lower Limit Preset Data are recorded in NOV RAM (Non-Evaporating RAM) so that the data can not be extinguished even in case of power-failures.

In case Upper & Lower Limits are changed or registered by RS-232C (OP-4), those registered data become effective (Over-writing).

CAUTION

- (1) Upper & Lower Limit Comparator Function is optional.
- (2) Standard TD-310A has HI, LO, HI OUT and LO OUT marked on the front and rear panels though, those are for the optional functions.

2 0) HYSTERESIS FUNCTION

20-1. What is Hysteresis ?

It is to delay Off-Timing of Upper & Lower Limit Relay.

Normally Upper Relay starts ON, when a weight value exceeds its upper limit setting value and it turns OFF, when it drops down from its upper limit setting value.

However, if Hysteresis Width is preset by the following steps, Relay works to OFF only when a weight value drops down from the level of its Upper Limit Setting Value and further to Hysteresis Width.

Thus, Relay OFF Timing can be delayed.

20-2. SETTING OF HYSTERESIS WIDTH

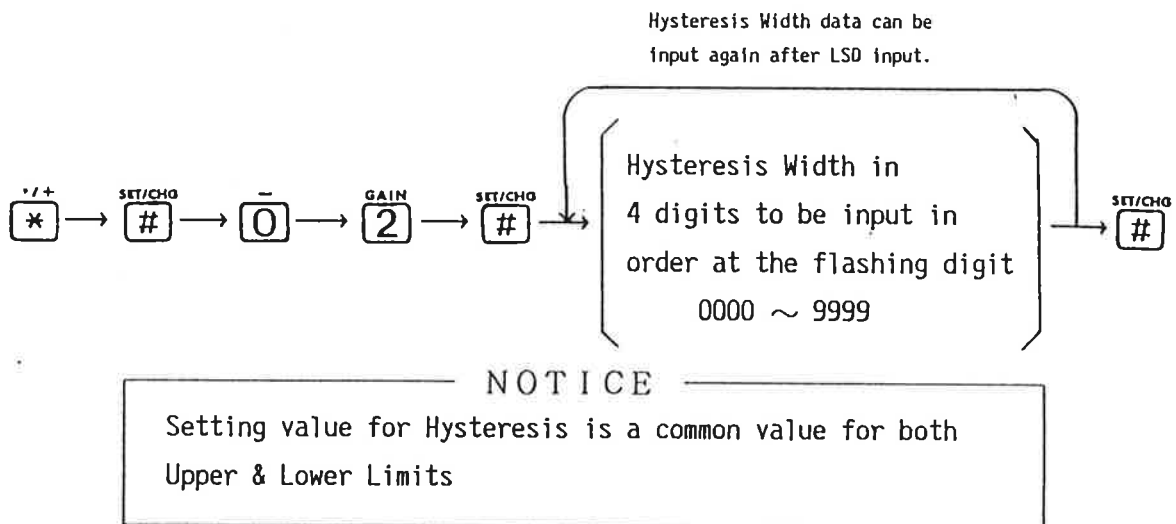

20-3. COMPARISON CONDITIONS

20-3-1. UPPER LIMIT RELAY AND LED DISPLAY

ON Condition : Displayed Value > Upper Limit Setting Value

OFF Condition : Displayed Value < Upper Limit Setting Value

20-3-2. LOWER LIMIT RELAY AND LED DISPLAY

ON Condition : Displayed Value < Lower Limit Setting Value

OFF Condition : Displayed Value > Lower Limit Setting Value

20-3-3. The above conditions in 20-3-1 and 20-3-2 are effective for Minus Areas as well.

20-4. OPERATION TIME CHART OF UPPER & LOWER LIMIT RELAYS

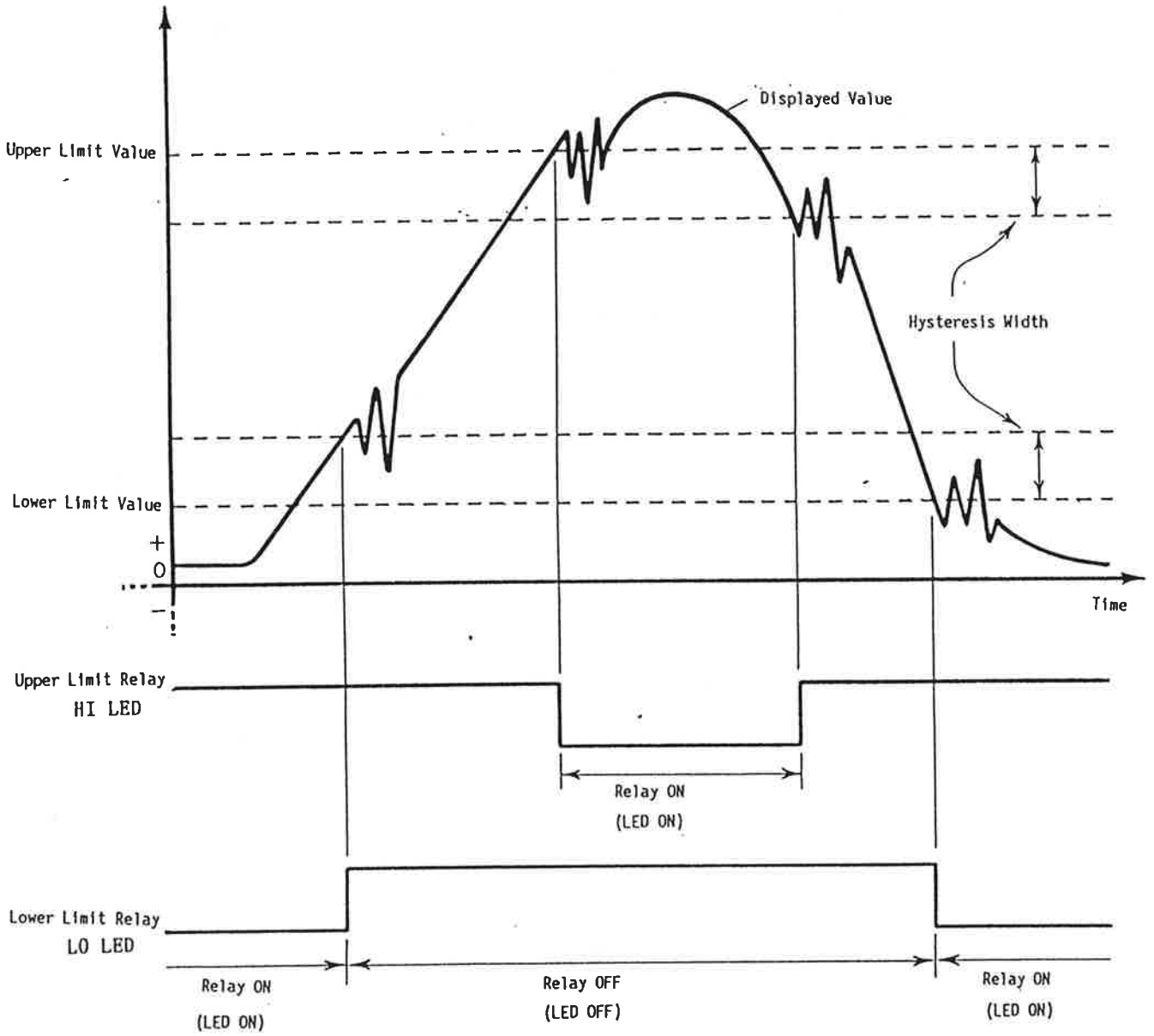

2 1) HOLD MODE (OP-2. TD-3102)

21-1. What does HOLD mean ?

HOLD is to to keep an indicated value of transducer. By selecting Mode Switch, it can hold the highest value (i.e. Peak-Value), or any value desired to be held. Peak-Hold is convenient to measure a very fast impulse physical phenomena such as crash, and a maximum value of signals in motion.

A Sample-Hold is suitable for a measurement related to automatic machines.

21-2. HOLD MODE SELECTION

Mode Selection can be done as follows.

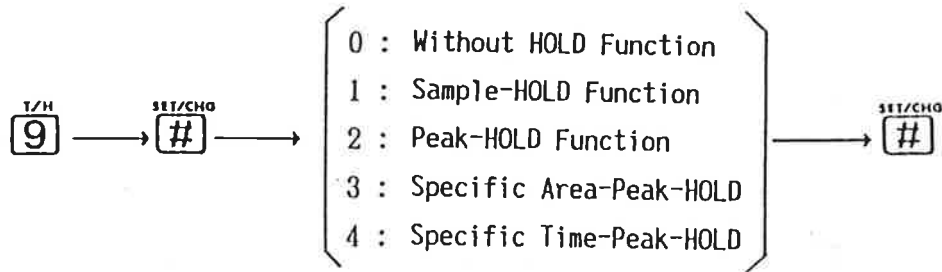

NOTICE

HOLD Mode is registered in NOV RAM (Non-Evaporating RAM) so that the data can be kept even in cases of power-failures. When HOLD Function is not used, 0 must be registered.

21-3. SAMPLE-HOLD OPERATION

21-3-1. Set HOLD Mode 1 (Sample-HOLD).

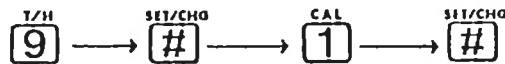

21-3-2. When making Sample-HOLD by Key-Switch in the front panel, make Terminal 9, 11 (T/H) and 12 (H/M) released.

NOTICE

Key 9 (T/H) in the front panel works for both TRACK/HOLD Functions. Function is changed from TRACK to HOLD repeatedly by pushing Key 9 (T/H). When HOLD LED is on, it is in HOLD Mode.

21-3-3. The following is SAMPLE-HOLD TIME CHART operated by Key 9 (T/H) in the front panel.

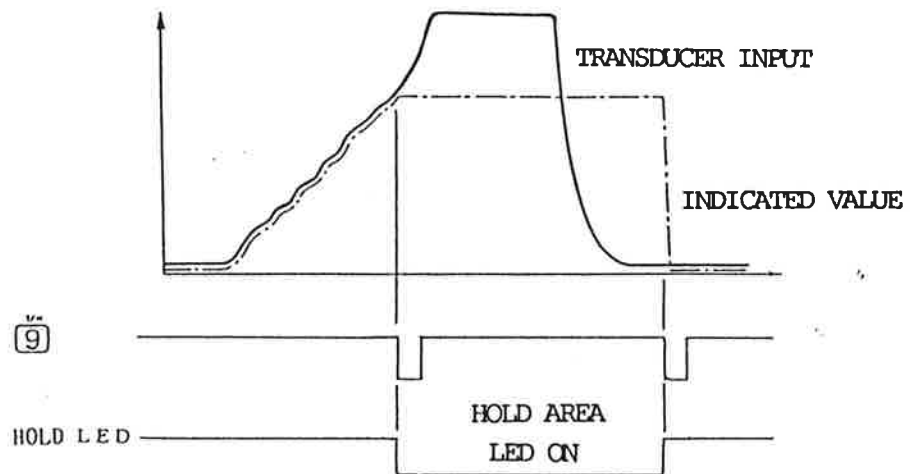

21-4. SAMPLE-HOLD : HOLD COMMANDED BY EXTERNAL SIGNAL

21-4-1. Connect Terminal 9 and 11 (T/H) together.

Immediately after short-circuited, the indicated value is in HOLD and HOLD LED turns on.

21-4-2. Disconnect Terminal 9 and 11 (T/H) to make HOLD released.

Immediately after disconnected, a transducer signal is indicated and HOLD LED turns off.

21-4-3. EXAMPLE OF T/H INPUT CIRCUIT AND EXTERNAL ACTIVE CIRCUIT

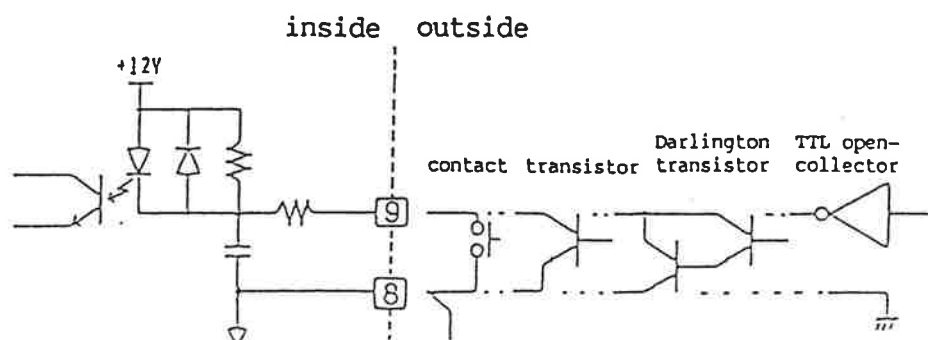

21-4-4. EXTERNALLY COMMANDED (T/H) SAMPLE-HOLD TIME CHART

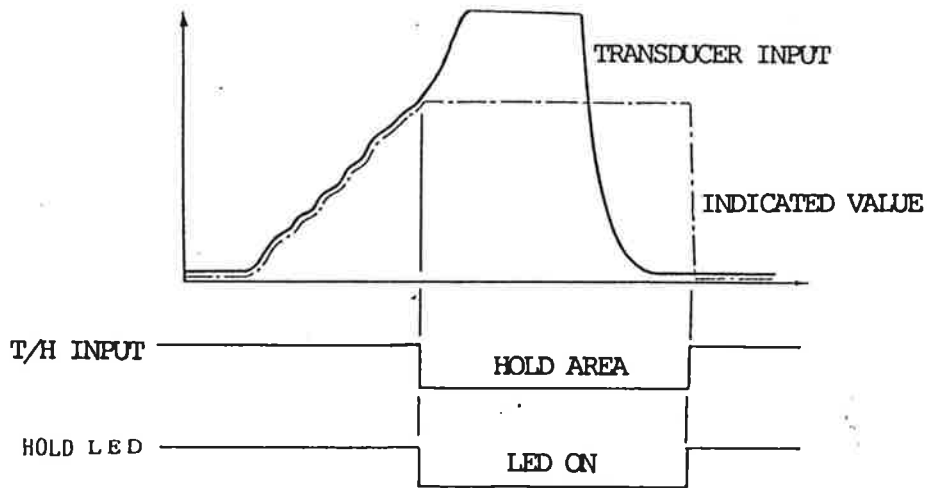

Refer to the detailed Time Chart in the page

NOTICE

DEFINITION OF TRACK/HOLD

TRACK ... Conditions where indicated values are corresponding to Input Values from Transducer.

HOLD Conditions where an indicated value is kept by HOLD MODE.

T/H TRACK/HOLD (T stands for TRACK, and H for HOLD)

CAUTION

In case of power-failures, all values in the condition of HOLD are extinguished. If External Input is kept in HOLD condition, unstable values will be kept in HOLD after the power is on again. So, make sure to reset External Input HOLD.

21-5. PEAK-HOLD OPERATION

21-5-1. Set HOLD Mode at 2 (PEAK-HOLD MODE).

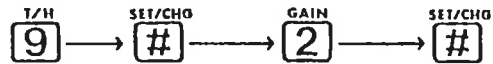

21-5-2. How to set PEAK-HOLD by Key-Switch Operation.

21-5-2-1. OPEN CONNECTION

Make Terminal 9 and 11 (T/H) open.

21-5-2-2. START OF PEAK-HOLD

Get PEAK-HOLD started by pushing Key **T/H** [9], HOLD LED is now on. Since then, PEAK-VALUE of Transducer Signal will be kept.

21-5-2-3. RESET OF PEAK-HOLD

Reset PEAK-HOLD by pushing again Key **T/H** [9]. HOLD LED turns off and now it is in TRACK condition (i.e. Indicating Transducer Input Signal).

21-5-2-4. PEAK-HOLD TIME CHART OPERATED BY KEY **T/H** [9]

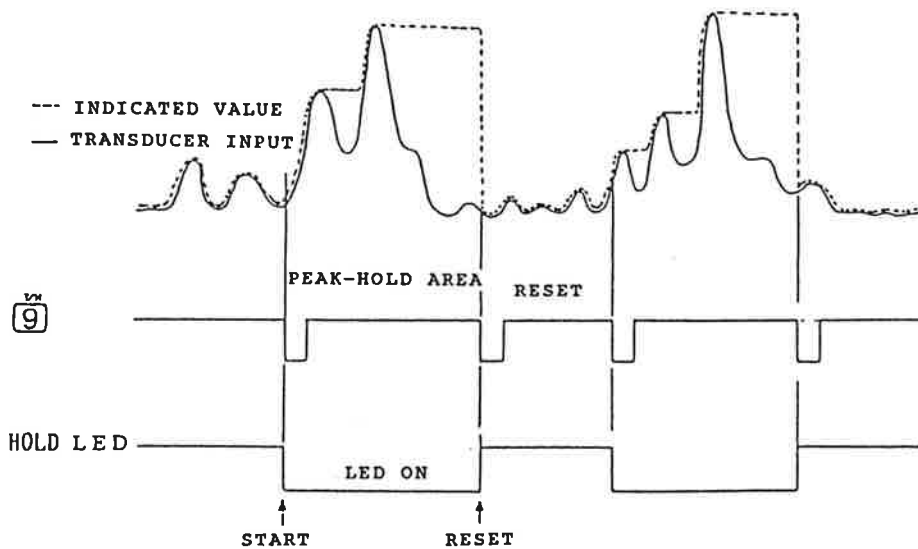

21-5-3. PEAK-HOLD Operation by External Command

EXAMPLE OF T/H INPUT CIRCUIT AND EXTERNAL ACTIVE CIRCUIT
inside outside

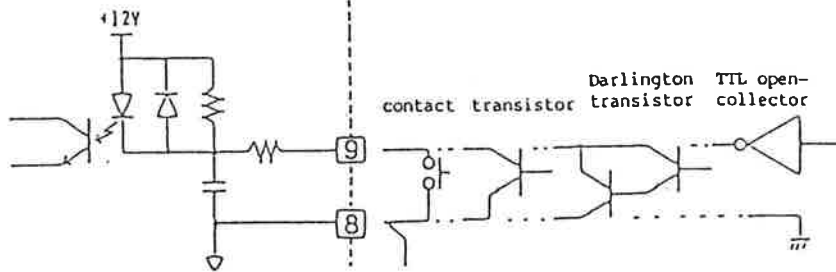

21-5-3-1. START OF PEAK-HOLD

Make Terminal 9 and 11 (T/H) short-circuited.

Now, HOLD LED turns on showing PEAK-HOLD Function started.

21-5-3-2. RESET OF PEAK-HOLD

Make Terminal 9 and 11 (T/H) disconnected.

Now, HOLD LED turns off showing it is in TRACK condition.

21-5-3-3. PEAK-HOLD TIME CHART OPERATED BY EXTERNAL COMMAND (T/H)

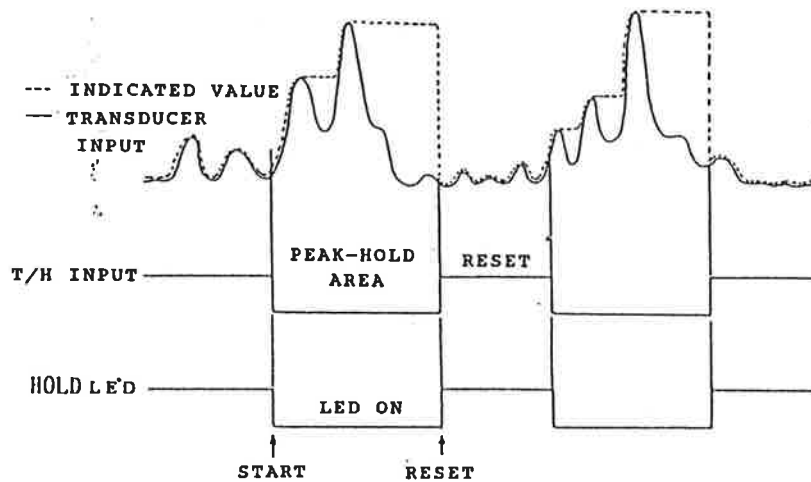

CAUTION

- (1) PEAK-HOLD is an optional function.
Standard Model has the similar function. But it can not keep the function in a fast moving.
- (2) PEAK-VALUE is calculated by arithmetical method including Minus Factor as well. The largest value of plus direction is to be held as PEAK-VALUE.
- (3) When a power-failure, PEAK-HOLD Values are all extinguished. If External Input left in PEAK-HOLD, only unstabilized data will be in HOLD condition after power is on again.
Reset External Input HOLD.
- (4) DO NOT operate Key 9 in the front panel, while an external control is operating.

21-6. SPECIFIC AREA-PEAK-HOLD

Set HOLD MODE 3 (Specific Area Peak Hold).



21-7. PEAK-HOLD BY KEY-SWITCH IN THE FRONT PANEL

21-7-1. Make Terminal 9, 11 (T/H) and 12 (H/M) open.

Now, Key 9 (T/H) in the front panel works as TRACK/HOLD Function Key.
 Every time Key 9 is pushed, Function is shifting like PEAK-HOLD → HOLD → TRACK → PEAK-HOLD → HOLD → TRACK → PEAK-HOLD
 Operation of each Function is checked by HOLD LED.

ON	FLASHING	OFF
at PEAK-HOLD	at HOLD	at TACKING

21-7-2. START OF PEAK-HOLD

Push Key 9 (T/H). HOLD LED is now ON.

Since then, PEAK-VALUE of Input from Transducer will be kept.

21-7-3. START OF HOLD

Push Key 9 (T/H). HOLD LED is now FASHING.

PEAK-HOLD Value is now kept until Key 9 will be pushed again.

21-7-4. RESET OF PEAK-HOLD

Push Key ^{T/H}9 HOLD LED turns OFF and becomes in TRACKING Condition
 (Input Value from Transducer is displayed.)

21-7-5. PEAK-HOLD TIME CHART BY KEY ^{T/H}9 OPERATION

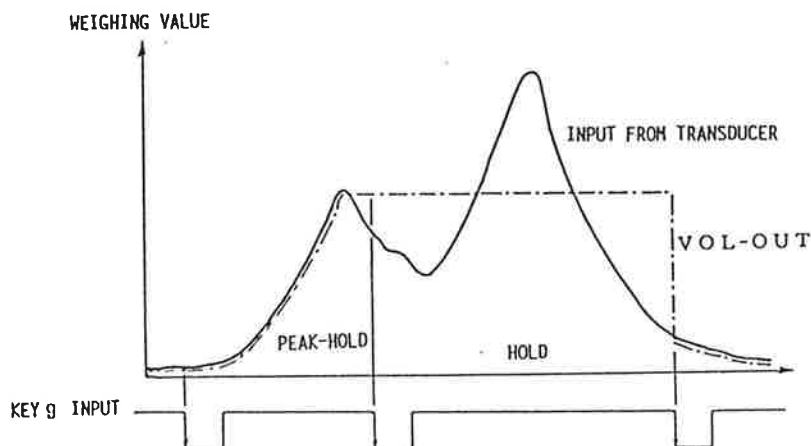

21-8. SPECIFIC AREA-PEAK-HOLD OPERATED BY EXTERNAL COMMAND

21-8-1. EXAMPLE OF H/M, T/H INPUT CIRCUIT AND EXTERNAL ACTIVE CIRCUIT

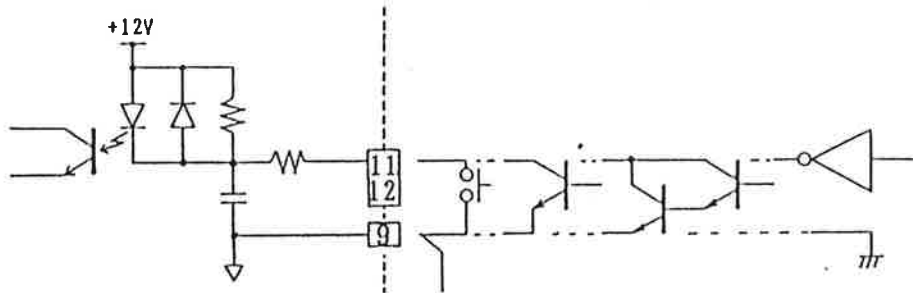

21-8-2. START OF PEAK-HOLD

Make Terminal 9 and 12 (H/M) short-circuited. HOLD LED turns on. Then, PEAK-VALUE of Transducer will be kept.

21-8-3. START OF HOLD

Make Terminal 9 and 12 (H/M) open. Then, a value of PEAK-HOLD is kept.

21-8-4. RESET OF PEAK-HOLD

Make Terminal 9 and 11 (T/M) short-circuited. HOLD LED turns off and now it is in TRACKING Conditions (i.e. Input Value from Transducer is displayed).

21-8-5. PEAK-HOLD TIME CHART BY EXTERNAL COMMAND (H/M) AND (T/H)

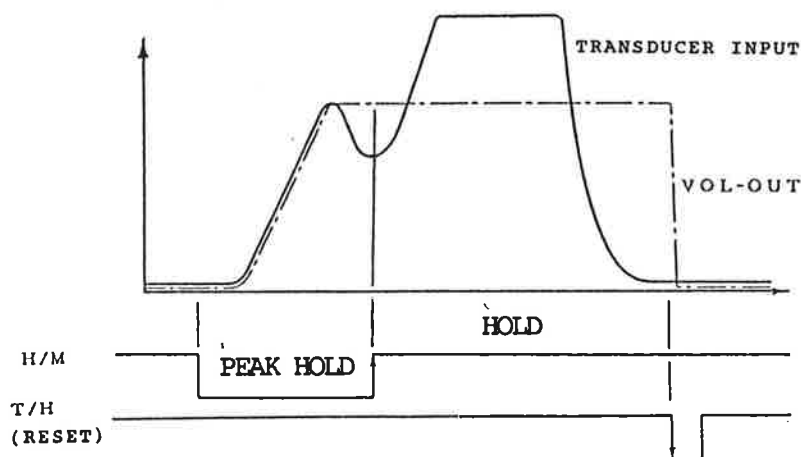

Refer to the detailed Time Chart in the page 52.

21-9. HOLD-MODE 4

21-9-1. SPECIFIC TIME-PEAK-HOLD

21-9-1-1. Set HOLD MODE 4 as follows.

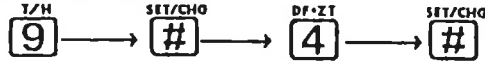

21-9-1-2. Set a time (0.01 ~ 99.99 Seconds) for PEAK-HOLD as follows.

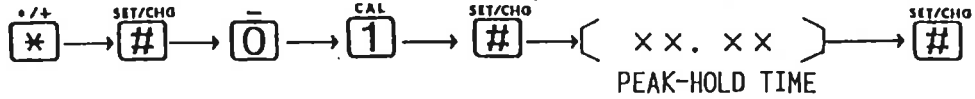

21-9-2. HOLD SET BY KEY-SWITCH IN THE FRONT PANEL

21-9-2-1. Make Terminal ^{T/H}9 (T/H) and 1 1 (H/M) open.

Key 9 works as TRACK/HOLD Key. If it is pushed once, it will get in PEAK-HOLD condition and after a preset time passes, it will get in HOLD. If it is pushed again, it will get in TRACKING condition.

Thus, every time Key ^{T/H}9 is pushed, this cycle is repeated.
 Each condition is indicated by HOLD LED as follows.

ON	FLASHING	OFF
At PEAK-HOLD	At HOLD	At TRACKING
●	☀	○

21-9-2-2. START OF PEAK-HOLD

Push Key ^{T/H}9. HOLD LED turns on indicating the start of PEAK-HOLD. Since then, the Peak Value of Input from Transducer will be kept in the hold-condition.

21-9-2-3. START OF HOLD

After a setting time passes, HOLD LED is flashing. At this moment, the value of PEAK-HOLD is to be kept until Key ^{T/H}9 will be pushed.

21-9-2-4. RESET OF PEAK-HOLD

Push Key ^{T/H}9. HOLD LED turns off, and then it will get into TRACKING condition (i.e. display of Input Value of Transducer).

21-9-2-5. PEAK-HOLD TIME CHART BY KEY $\boxed{9}^{VH}$

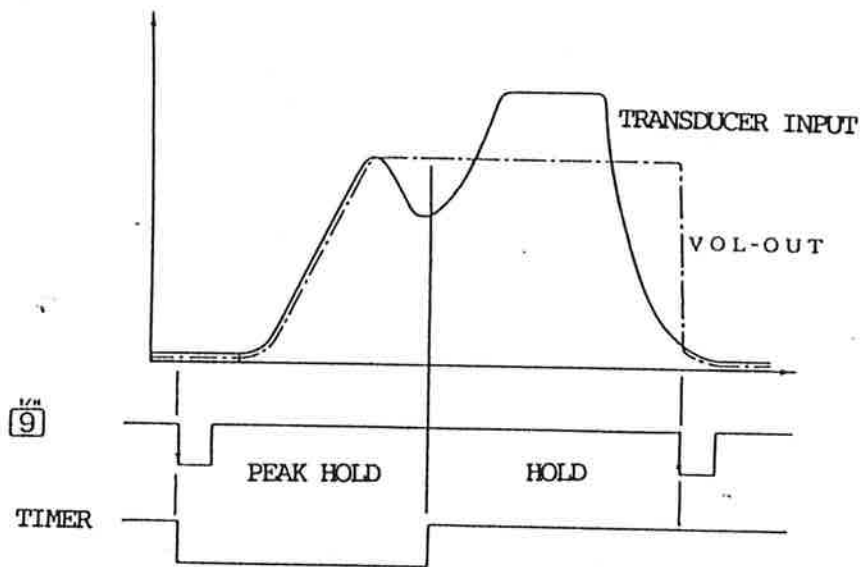

21-9-3. SPECIFIC TIME-PEAK-HOLD BY EXTERNAL COMMAND

21-9-3-1. EXAMPLE OF H/M, T/H INPUT CIRCUIT AND EXTERNAL ACTIVE CIRCUIT

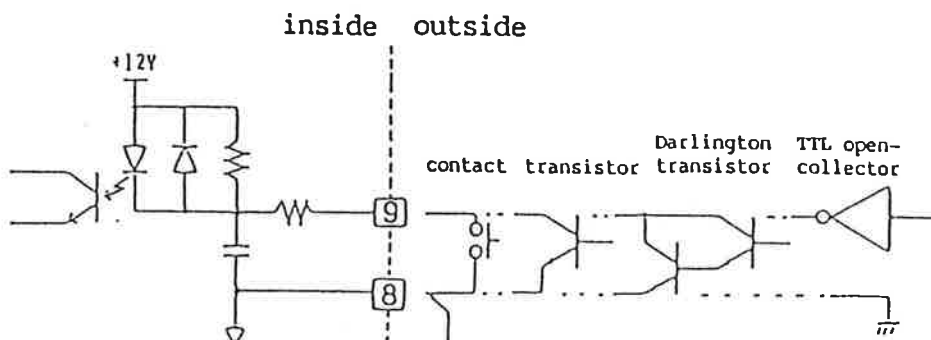

21-9-3-2. START OF PEAK-HOLD

Make Terminal 9 and 12 (H/M) short-circuited.

HOLD LED turns on showing the start of PEAK HOLD.

Since then, the Peak-Value of Transducer will be kept.

21-9-3-3. START OF HOLD

After a setting time passes, HOLD LED is flashing. At this moment, a value being kept as PEAK-HOLD is to be kept until it will be reset.

21-9-3-4. RESET OF PEAK-HOLD

Make Terminal 9 and 11 (T/H) short-circuited. HOLD LED turns off.

It will get into TRACKING condition (i.e. display of input value from transducer).

21-9-3-5. PEAK-HOLD TIME CHART BY EXTERNAL COMMAND (H/M), (T/H)

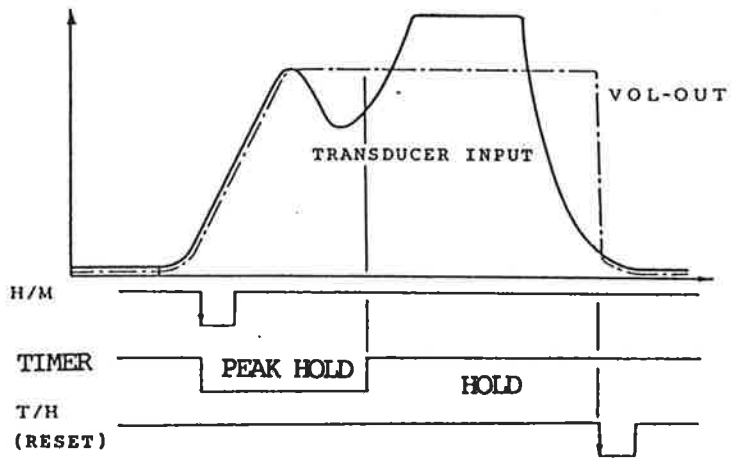

21-9-4. MODE 1 SAMPLE-HOLD TIME CHART

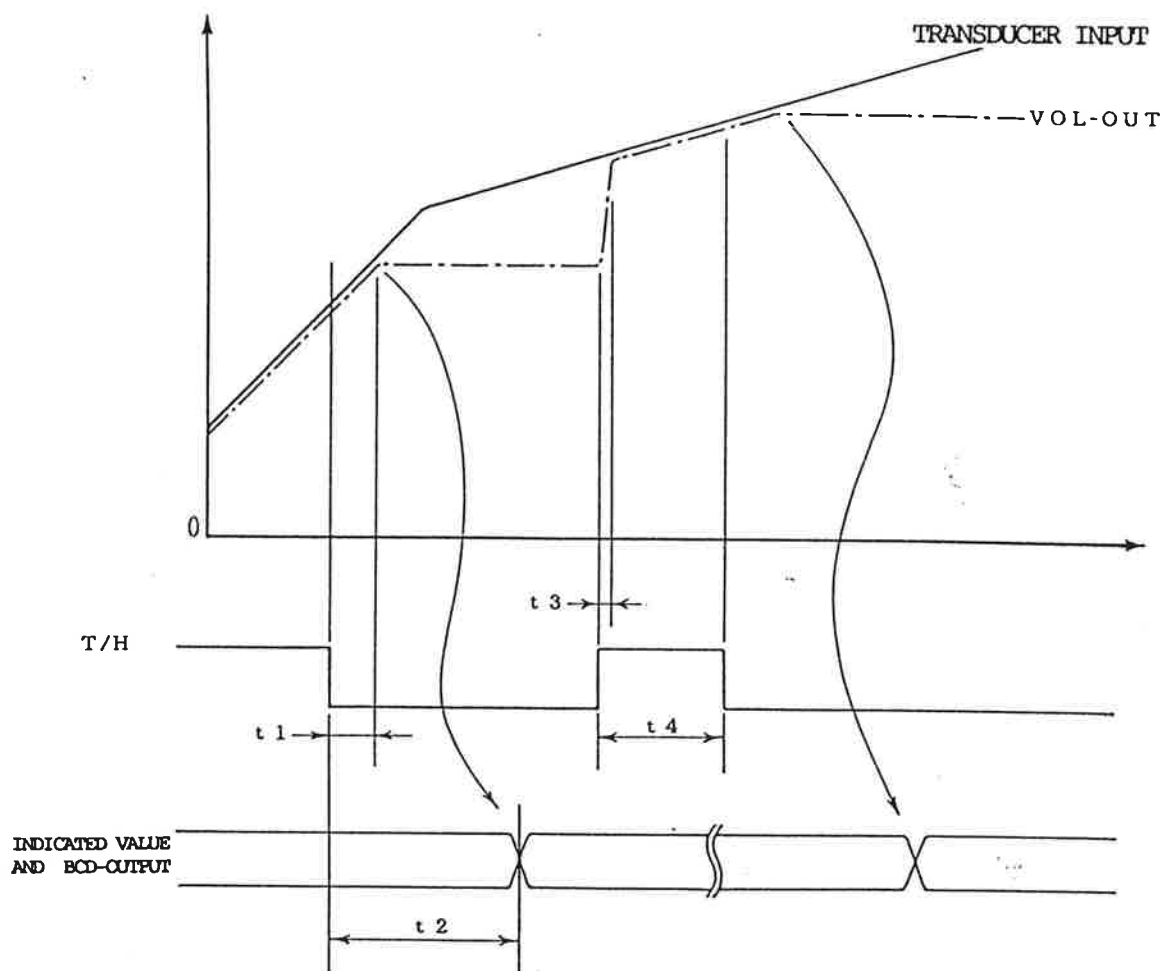

t1 : MAX 1mS
 t2 : MAX 500mS
 t3 : MAX 0.1mS
 t4 : MIN 1mS

- t1 : Time, from short-circuit of T/H Input (OFF → ON) to making Analog Value of Transducer kept in HOLD.
- t2 : Time, until A/D converging the Analog Value kept in HOLD. (See NOTE hereunder.)
- t3 : Time, from making T/H Input open (ON → ON') to releasing ANALOG-HOLD.
- t4 : Time, Minimum Track (Reset) necessary to make Display in HOLD released.

NOTE : There is Low-Pass-Filter inserted between Analog-Hold Circuit and A/D Converter so as to balance the oscillating of Analog data. (See Block Diagram.)
 Therefore, an actual HOLD (Displayed Value) will be delayed by 500 mS.

21-9-5. MODE 2 PEAK-HOLD TIME CHART

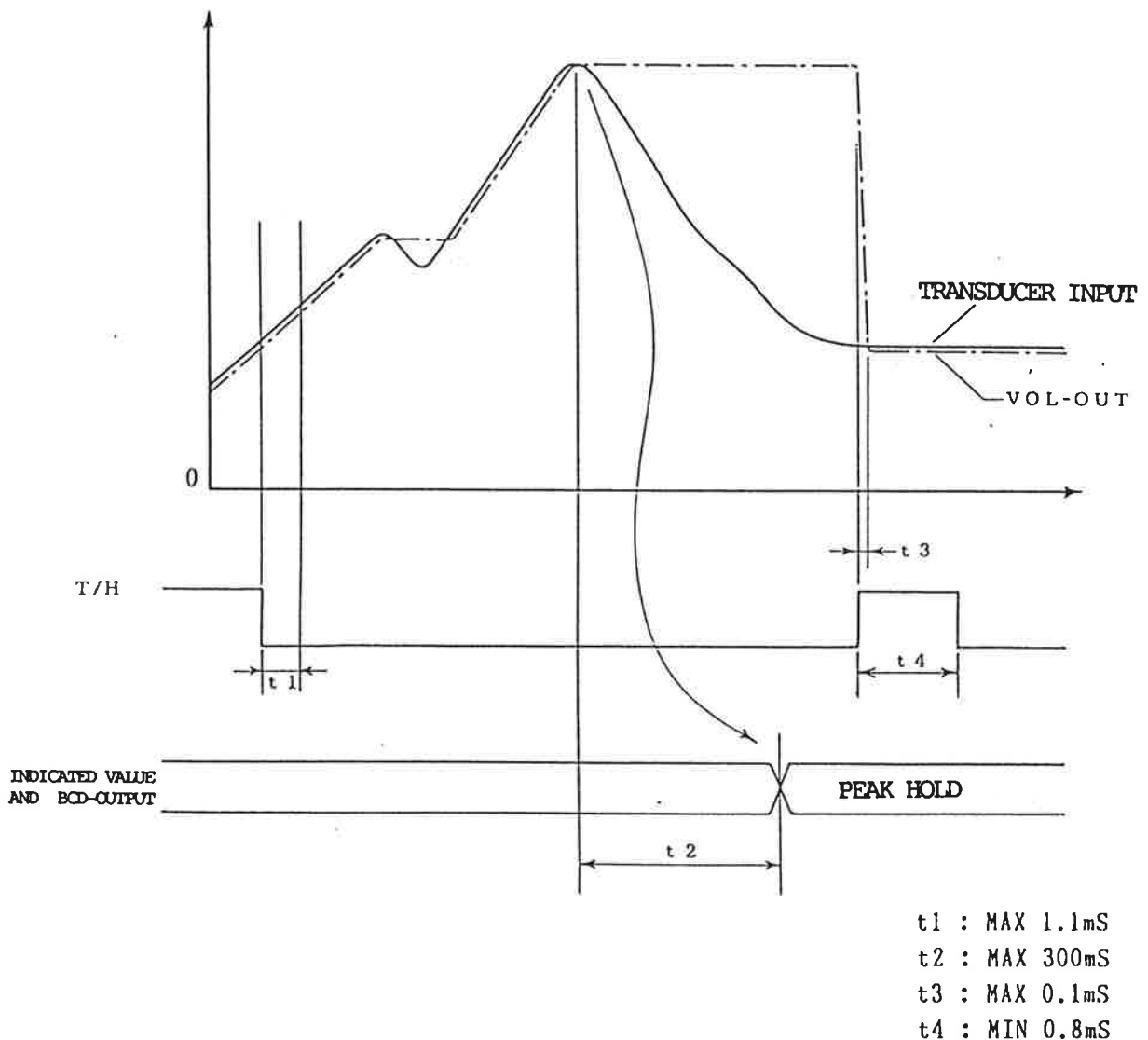

- t1 : Time, from making T/H Input short-circuited (OFF → ON) to starting to make Analog-Value of Transducer PEAK HOLD.
- t2 : Time, until A/D Converting Analog-Value in PEAK-HOLD.
(See NOTE hereunder.)
- t3 : Time, from making T/H Input (ON → OFF) open to releasing Analog PEAK-HOLD
- t4 : Time, Minimum Track (Reset) Time necessary to reset displayed value in PEAK-HOLD.

NOTE : There is Low-Pass-Filter inserted between Analog-Hold Circuit and A/D Converter so as to balance the oscillating of Analog data. (See the Block Diagram.)

Therefore, an actual HOLD (Displayed Value) will be delayed by 300 mS.

21-9-6. MODE 3 SPECIFIC AREA-PEAK-HOLD TIME CHART

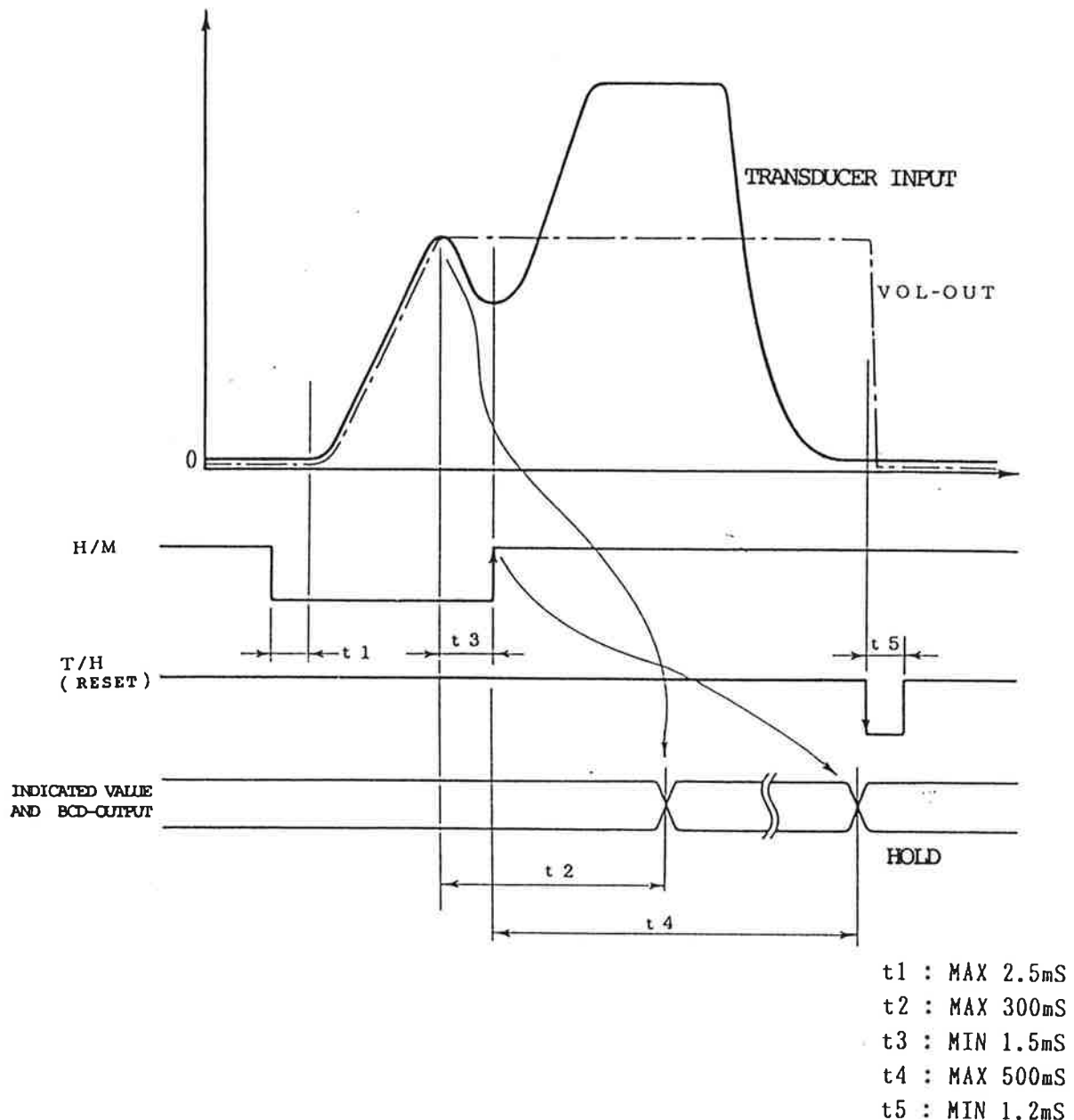

- t_1 : Time, between making H/M Input short-circuited. (OFF → ON) and starting PEAK-HOLD of Analog-Value from Transducer
- t_2 : Time, until A/D Converting of Analog Value kept in PEAK-HOLD. (See NOTE hereunder.)
- t_3 : Time, Minimum PEAK-HOLD Time to ensure to hold PEAK-Value. till Analog-Hold being released
- t_4 : Time, to delay Digital-Hold so as to ensure A/D converting Analog-Value kept in HOLD. (See NOTE hereunder.)

NOTE : There is Low-Pass-Filter inserted between Analog-Hold Circuit and A/D Converter so as to balance the oscillating of Analog data. (See Block Diagram.)

Therefore, an actual HOLD (Displayed Value) will be delayed.

21-9-7. MODE 4 SPECIFIC TIME-PEAK-HOLD TIME CHART

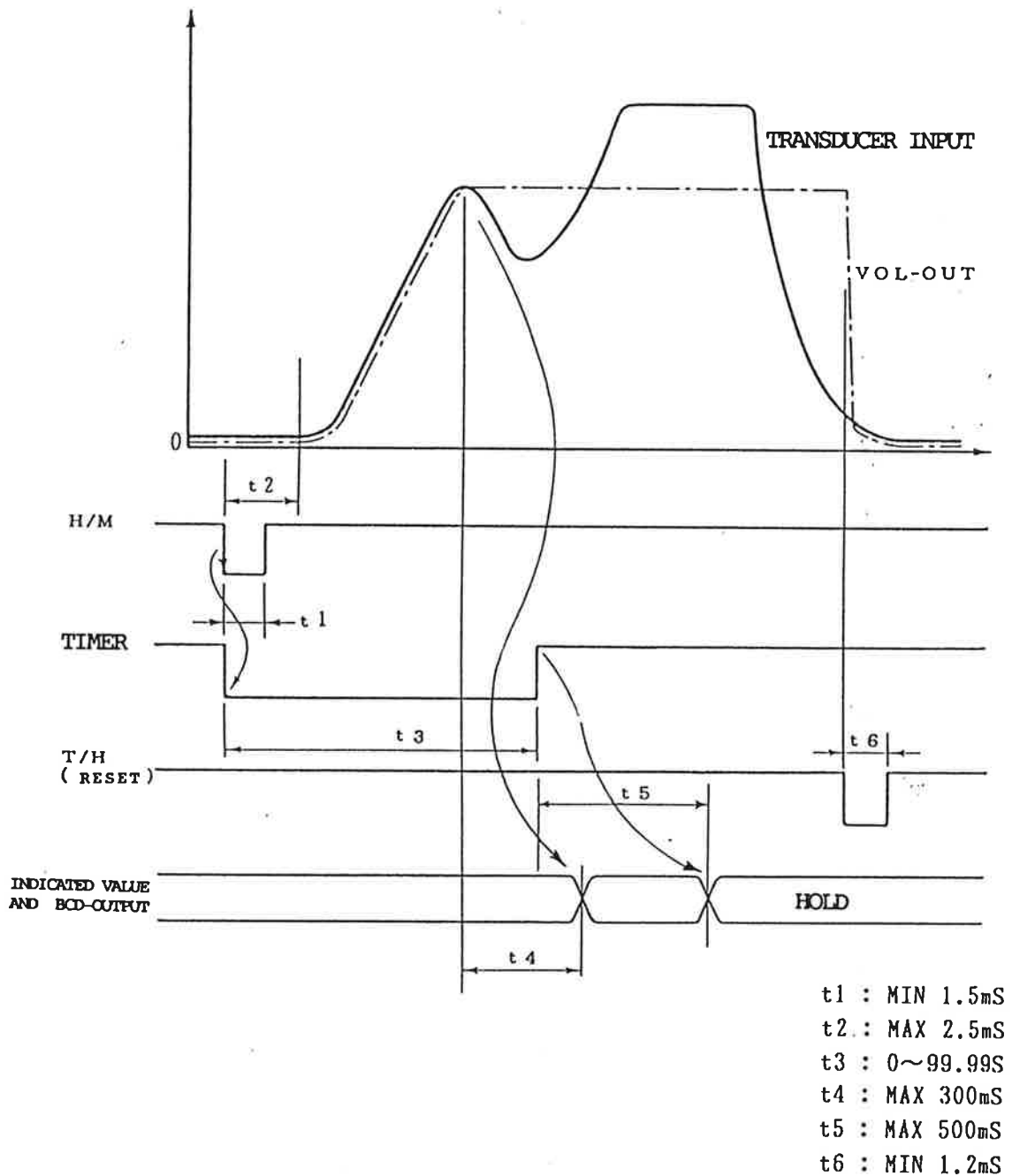

- t1 : Minimum Pulse Width to enable trigger Timer of Internal Peak-Hold
- t2 : Time, starting to have Timer triggered
till starting PEAK-HOLD of Analog Value from Transducer
- t3 : Time, Setting Internal Peak-Hold Timer
- t4 : Time, until A/D Converting Analog Time kept in PEAK-HOLD
(See NOTE hereunder.)

- t5 : Time, to delay Digital-Hold so as to ensure A/D converting Analog-Value kept in HOLD. (See NOTE hereunder.)
- t6 : Minimum Pulse Width necessary to reset displayed value in PEAK-HOLD.
- NOTE : There is Low-Pass-Filter inserted between Analog-Hold Circuit and A/D Converter so as to balance oscillating Analog Data. (See Block Diagram.)
- For this reason, an actual HOLD (Displayed Value) will be delayed.

2 2) BCD DATA OUTPUT (OP-3. TD-3103)

BCD Data Output is a sort of Interface to get BCD Coded Data from Indicated values of TD-310A . This Interface is convenient to proceed a control, suming, recording, etc. by connecting TD-300A to Computer, Process Controller, Sequencer, etc. Input/Output circuits are electrically insulated from Internal Circuits of TD-300A by Photo-Isolator.

22-1. OUTPUT CONNECTOR PIN ASSIGNMENT :

1	C O M	2 6	
2	Data 1 Output	2 7	
3	" 2 "	2 8	
4	" 4 "	2 9	
5	" 8 "	3 0	
6	" 1 0 "	3 1	
7	" 2 0 "	3 2	
8	" 4 0 "	3 3	
9	" 8 0 "	3 4	
1 0	" 1 0 0 "	3 5	
1 1	" 2 0 0 "	3 6	
1 2	" 4 0 0 "	3 7	
1 3	" 8 0 0 "	3 8	
1 4	" 1 0 0 0 "	3 9	
1 5	" 2 0 0 0 "	4 0	
1 6	" 4 0 0 0 "	4 1	
1 7	" 8 0 0 0 "	4 2	Minus (POLARITY)
1 8		4 3	
1 9		4 4	
2 0		4 5	
2 1		4 6	OVER OUTPUT
2 2		4 7	
2 3		4 8	
2 4		4 9	EOC (CONVERSION FINALIZED)
2 5		5 0	BCD HOLD INPUT

☆ Output Connector : 57-40500 (DDK Made)

☆ Open Pins are internally used, and, therefore, they should not be connected outside.

22-2. SIGNAL LOGIC

- (1) BCD DATA OUTPUT : Negative Logic / Positive Logic
(To be specified when ordering)
- (2) POLARITY OUTPUT : Negative Logic (When Minus, "L")
- (3) OVER OUTPUT : Negative Logic (When Over, "L")
- (4) EOC (CONVERSION FINALIZED) : Negative Logic
- (5) BCD HOLD INPUT : Negative Logic (When "L", BCD Data Hold)

22-3. EQUIVALENCE CIRCUIT

- (1) BCD DATA OUTPUT AND OTHERS

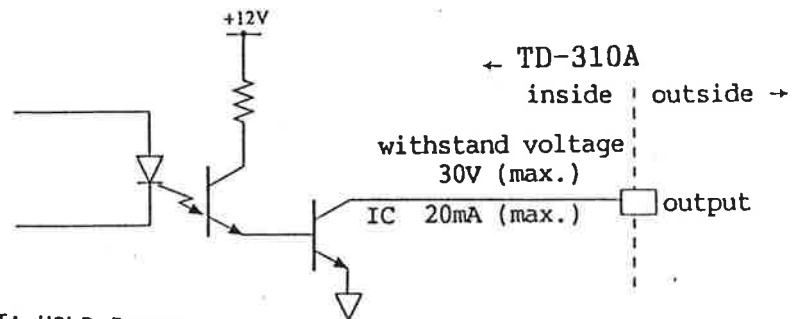

- (2) BCD DATA HOLD INPUT

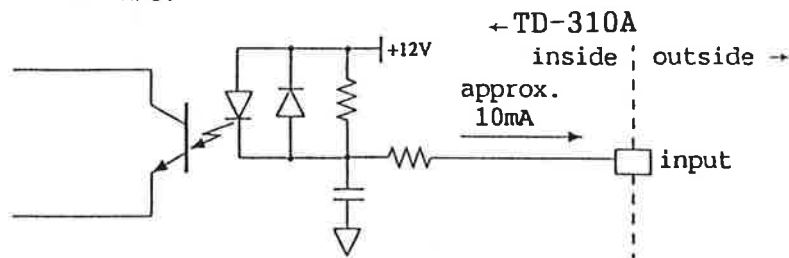

22-4. SIGNAL TIMING

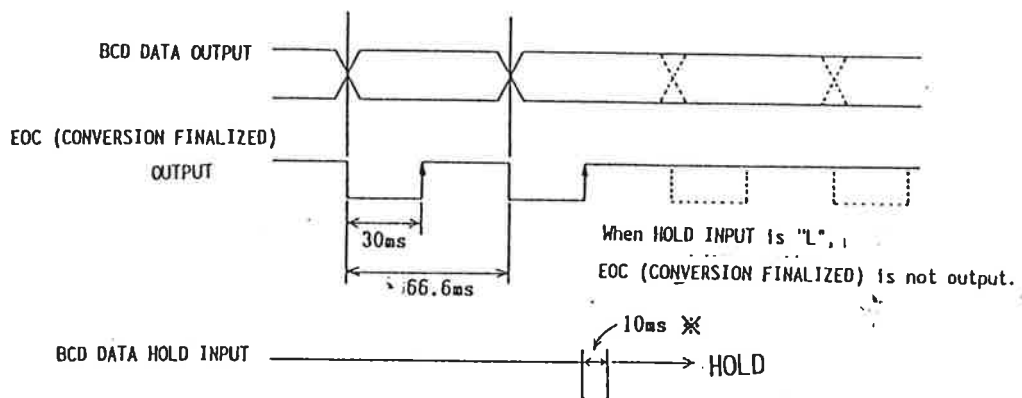

※ It takes about 10mS to execute HOLD Function actually after input of HOLD-Signal.

22-5. DATA ACQUISITION ASSURANCE

- (1) When Data Acquisition by EOC (Conversion Finalized), be sure to acquire BCD Data, Polarity and Over Data within 30mS right after the rising edge (when changing from "L" to "H").
- (2) When Data Acquisition by BCD DATA HOLD, make BCD DATA HOLD INPUT "L" and then within 10mS BCD DATA must be acquired. During "L" BCD DATA will not be changed.

CAUTION

- (1) BCD DATA OUT is optional.
- (2) Displayed Value is not be held by BCD DATA HOLD INPUT.
- (3) BCD DATA are always Indicated Values of Input from Transducer. While Key operating, Setting Value is displayed, but BCD DATA are Indicated Values of Input from Transducer.

2 3) RS-232C INTERFACE (OP-4, TD-3104)

RS-232C Communication Interface is to read out an indicated value and/or a present status of TD-310A , and also to write a Lower and Upper Limits into TD-310A .

This interface is convenient and useful when TD-310A is connected to a computer, or processing controller, or sequencer, or recorder, or any other.

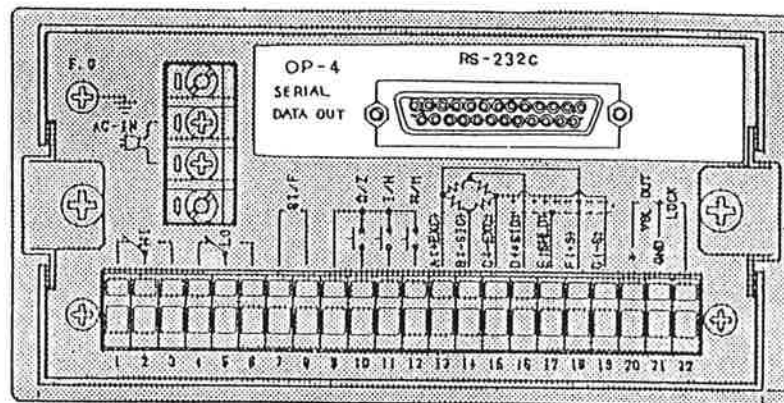

23-1. SPECIFICATION

- 23-1-1. SIGNAL SYSTEM : RS-232C FULL DUAL SYSTEM
- 23-1-2. TRANSMISSION SYSTEM : START STOP SYNCHRONOUS
- 23-1-3. TRANSMISSION SPEED : 4,800 BPS
- 23-1-4. BIT CONFIGURATION : START 1 BIT
DATA 7 BIT
PARITY 1 BIT (ODD)
STOP 1 BIT
- 23-1-5. OUTPUT CODE : ASCII

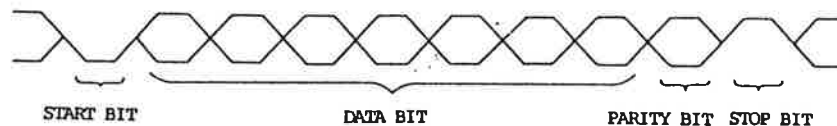

23-2. OUTPUT CONNECTOR PIN ASSIGNMENT

PIN NO.	SIGNAL NAME	REMARKS
2	T X D	OUTPUT DATA
3	R X D	INPUT DATA
7	S G	SIGNAL GROUND
4	R T S	"H" ALWAYS
2 0	D T R	"H" ALWAYS

23-3. OUTPUT CONNECTOR : JAE DBLC-J25SA or Equivalent

23-4. OUTPUT FORMAT

DATA CONSTRUCTION

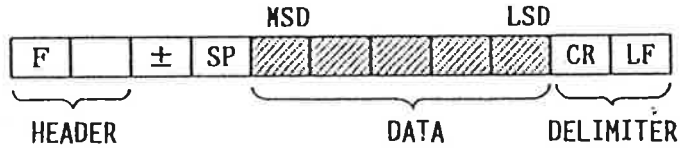

SP SPACE

MSD ... MOST SIGNIFICANT DIGIT

LSD ... LEAST SIGNIFICANT DIGIT

23-5. MODE SELECTION

23-5-1. MODE 0 : Sequential Transmission of Indicated Value and Status

23-5-2. MODE 1 : Transmission of a specific data once, when commanded.

Writing/Reading of Upper and Lower Limits

23-5-3. SELECTION PROCEDURE

MODE 0 SELECTION :

M	O	CR
---	---	----

 (When power-on, it is set to MODE 0.)

MODE 1 SELECTION :

M	I	CR
---	---	----

23-6. UTILIZATION OF MODE 0

By pushing Key

M	O	CR
---	---	----

, Data of "Indicated Value" and "Status" are transmitted repeatedly.

23-6-1. INDICATED VALUE

F	A	±	SP	①	②	③	④	⑤	CR	LF
---	---	---	----	---	---	---	---	---	----	----

When transmitting +1000,

F	A	+	SP	0	1	0	0	0	CR	LF
---	---	---	----	---	---	---	---	---	----	----

☆ If a decimal point is not included, 0 is to be in ① (MSD).

When transmitting -0.001,

F	A	-	SP	0	.	0	0	1	CR	LF
---	---	---	----	---	---	---	---	---	----	----

23-6-2. STATUS

F	B	SP	i	ii	iii	iv	v	vi	CR	LF
---	---	----	---	----	-----	----	---	----	----	----

i HI : When an indicated value is larger than Upper Limit Setting Value, "1" is to be transmitted.

Upper/Lower Limit Comparator is equipped, it indicates the operation of Upper Limit Relay.

ii LO : When an indicated value is smaller than Lower Limit Setting Value, "1" is to be transmitted.

Upper/Lower Limit Comparator is equipped, it indicates the operation of Lower Limit Relay.

- iii HOLD: When an indicated value is of HOLD Value, "1" is to be transmitted.
There are two different kinds of HOLD Functions (one is SAMPLE-HOLD and the other is PEAK-HOLD). In each function, it indicates a value in the HOLD condition preset and commanded by an external signal or T/H Key.
- iv ZT : When ZERO TRACKING Value is set, "1" is to be transmitted.
It indicates the operation of ZERO TRACING.
- v ALM : When it has a various kinds of errors or abnormal condition "1" is to be transmitted.
- vi MD : When an indicated value is of a value internally designated and is fluctuating over the range, "1" is to be transmitted showing an unstabled condition.

NOTICE

- (1) The above i ~ v are the same operations as the status display. (See 10-1 CONDITION INDICATOR UNIT.)
- (2) During Key-Switch operations, measured values are being indicated. However, at the status display, the conditions are indicated by LED (ON) and "1" is to be transmitted, when LED is ON.

23-7. UTILIZATION OF MODE 1

MODE 1 is to be selected by

M	1	CR
---	---	----

23-8. REQUEST COMMAND

Data requested by REQUEST COMMAND are to be transmitted only once.

23-8-1. REQUEST COMMAND OF INDICATED VALUE

By

R	A	CR
---	---	----

, the following INDICATED VALUES are to be transmitted.

R	A	±	SP	①	②	③	④	⑤	CR	LF
---	---	---	----	---	---	---	---	---	----	----

When +1000 is transmitted,

R	A	+	SP	0	1	0	0	0	CR	LF
---	---	---	----	---	---	---	---	---	----	----

☆ When a decimal point is not included, 0 will inter in ① (MSD).

when -0.001 is transmitted,

R	A	-	SP	0	0	0	1	CR	LF
---	---	---	----	---	---	---	---	----	----

23-8-2. REQUEST COMMAND OF STATUS

By

R	B	CR
---	---	----

, the following STATUS are to be transmitted.

R	B	SP	i	ii	iii	iv	v	vi	CR	LF
---	---	----	---	----	-----	----	---	----	----	----

STATUS

The i ~ vi are of the same format as MODE 0. (See 23-6-2.)

23-9. WRITE AND READ UPPER/LOWER LIMIT VALUES

23-9-1. WRITE (HOST → TD-310A)

W	A/B	SP	±					CR
---	-----	----	---	--	--	--	--	----

A : UPPER LIMIT VALUE
B : LOWER LIMIT VALUE

By this, Writings of Upper/Lower Limit Value Setting can be done from HOST Side.

Upper/Lower Limit Values set by Key-Switch are to be changed to those values set for writings.

23-9-2. READ

By

W	A/B	CR
---	-----	----

, read out the set value as per the following format.

W	A/B	±	SP	0					CR	LF
---	-----	---	----	---	--	--	--	--	----	----

SETUP VALUE

Set Values by Key-Switch and those of RS-232C are common. Here, it is possible to read out the values set by Key-Switch.

23-9-3. RE-TRANSMISSION AFTER WRITING

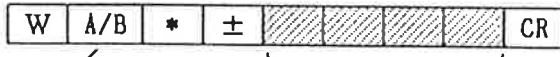

A : UPPER LIMIT VALUE SETUP VALUE
 B : LOWER LIMIT VALUE

By this, both Writings and Readings of Upper/Lower Limit Values can be doen at once. By the following format the set values can be retransmitted.

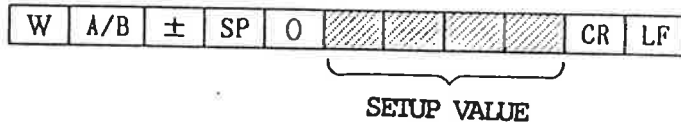

23-9-4. IN CASE COMMAND CANNOT BE RECOGNIZED.

When a command which can not be recognized is transmitted, its letters will be retransmitted as per the following format.

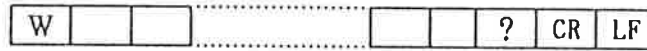

23-10. CONNECTION TO PERSONAL COMPUTER

23-10-1. CONNECTION TO PERSONAL COMPUTER BY THE FOLLOWING CONNECTION CABLE

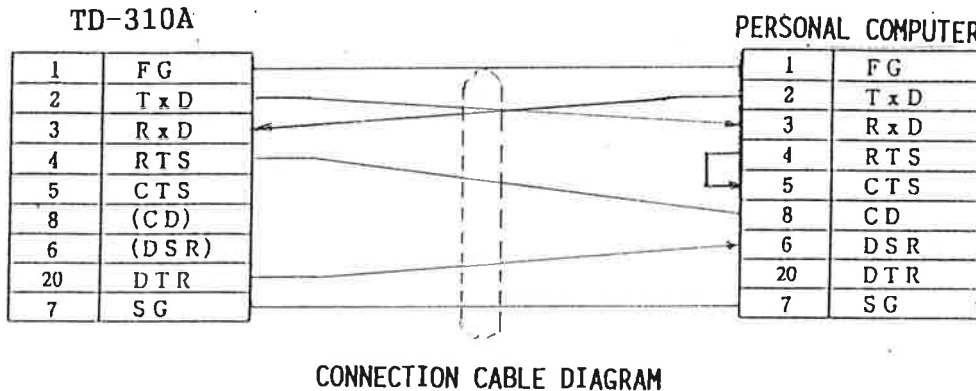

This connection diagram indicates for the cable when a personal computer is of DTE (Data Terminal Equipment) . In case of DCE (Data Circuit-Terminating Equipment), use a cable straightly connected with each signal line.

23-10-2. INITIALIZING RS232C OF PERSONAL COMPUTER

TRANSMISSION SPEED : 4800 BPS
 DATA BIT : 7 BIT
 PARITY BIT : 1 BIT (ODD)
 STEP BIT : 1 BIT
 CODE : ASCII

23-10-3. FOR PERSONAL COMPUTER, PROGRAMMING IS NECESSARY TO ACQUIST DATA.

CAUTION

- (1) RS-232C COMMUNICATION INTERFACE is optional.
- (2) Connect only an equipment with RS-232C Standards.
 If connected to other equipment, it casues troubles.

23-10-4. SAMPLE PROGRAM

This program describes in the form of BASIC and shows the indicated values and the status.

```

100 '
110 '
120 '
130 '
140 CONSOLE 0,25,0,1: SCREEN 0,0,0,1: WIDTH 80,25: CLS 3
150
160 LOCATE 10, 5: PRINT "O P - 4 SAMPLE PROGRAM"
170
180 LOCATE 23,16: PRINT "HI LO HOLD ZT ALM MD"
190
200 FOR I=0 TO 5
210 CIRCLE (I*50+190,120),5,7
220 NEXT
230
240 ' PARITY ODD , DATA 7 BIT , STOP BIT 1 , XON/XOFF→NO USE
250 OPEN "COM:071NN" AS #1
260
270 WHILE 1
280 RXD$(0)=INPUT$(1,#1)
290 IF RXD$(0)="F" THEN GOTO 300
    ELSE GOTO 280
300 FOR I=1 TO 10
310 RXD$(I)=INPUT$(1,#1)
320 NEXT
330
340 IF {RXD$(0)="F"} AND {RXD$(1)="A"} THEN GOSUB *DISP 'F A - INDICATED VALUE
350 IF {RXD$(0)="F"} AND {RXD$(1)="B"} THEN GOSUB *DISPSTS 'F B - STATUS
360 WEND
370 *DISP
380 LOCATE 30,10: PRINT RXD$(2);" ";RXD$(3);" ";RXD$(4);" ";
390 PRINT RXD$(5);" ";RXD$(6);" ";RXD$(7);" ";RXD$(8);
400 RETURN
410 *DISPSTS
420 FOR I=3 TO 8
430 IF RXD$(I)="1" THEN PAINT((I-3)*50+190,120),2,7
    ELSE PAINT((I-3)*50+190,120),0,7
440 NEXT
450 RETURN
460 END

```

23-10-5. EXECUTION OF SAMPLE PROGRAM

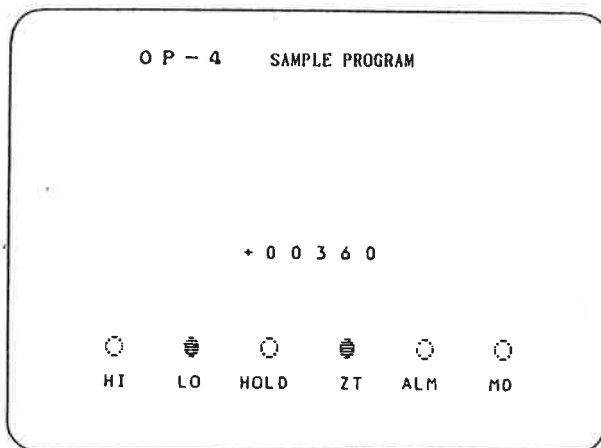

CAUTION

- (1) This program is for NEC PC-9801 N88-BASIC (86).
- (2) It will be necessary to modify for another computer.

24) ANALOG CONDITIONER (OP-6, TD-3106)

This is to add Functions of ZERO and GAIN Adjustments as well as of Constant Current Output of 4 - 20 mA to Analog Voltage Output Function. By this, TD-310A can be used as Signal Conditioner having an excellent response capability.

It is convenient to measure and record waveforms by connecting a recorder to TD-310A with OP-6.

24-1. CAL (CALIBRATION) SWITCH

Switch for Dummy Input of 1mV/V ($\pm 0.1\%$).

This function has no relation with Digital Indicated Value.

24-2. VOLTAGE OUTPUT TERMINAL

Terminal for Voltage Output Signal. VOL is Signal. G is Ground.

It can get Voltage Output Signal of $\pm 10V$ and can be used as Bipolar. Non-linearity is 0.03%/FS and Response is of 8kHz/-3dB.

24-3. CURRENT OUTPUT TERMINAL

Terminal for Current Output Signal. CUR is Signal. G is Ground.

4 - 20mA can be obtained in proportion to 0 - 10V.

Non-linearity is 0.1%/FS and Response is of 200Hz/-3dB.

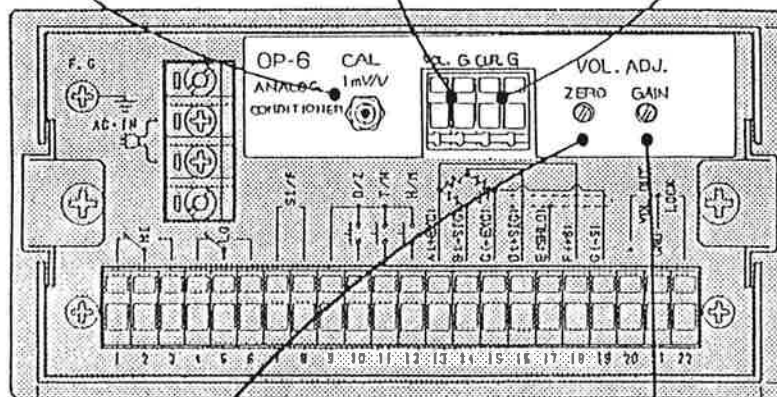

24-4. ZERO ADJUSTMENT TRIMMER

Range of Zero Adjustment is $\pm 0.3mV/V$ at Input Level.

When Current Output is used, adjustment should be made to 4mA by monitoring a current output.

24-5. GAIN ADJUSTMENT TRIMMER

Range of Gain Adjustment is 0.5 - 3.0mV/V at Input Level which can be set as Full Scale (Voltage Output 10V).

In case Current Output is used, adjustment should be made to 20 mA by monitoring a current output.

NOTICE

- (1) Voltage and Current Output are completely linked and when at 10V, it is 20mA, while at 0V, it is 4mA. It is not possible to adjust independently.
- (2) Voltage and Current Output are set at FS (10V, 20mA) at Input of 2mV/V when shipped from our factory. When adjusting, use a voltmeter and/or an ammeter with accuracy of 1/10,000.

- 24-6. LEAD OUT OF VOLTAGE OUTPUT SIGNAL
Connect VOL and G of TD-310A to an external equipment as shown in the right.

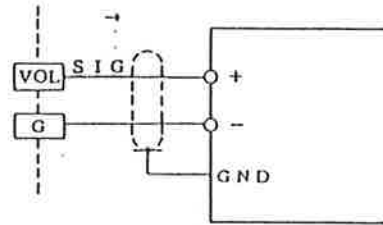

- 24-7. LEAD OUT OF CURRENT OUTPUT SIGNAL
Connect an external equipment (Load Resistance less than 350Ω) to CUR and G of TD-310A as shown in the right.

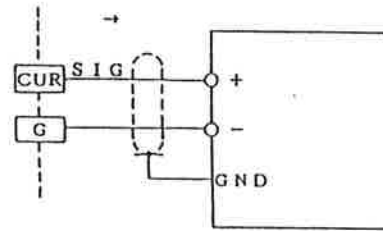

- 24-8. CAL (CALIBRATION) SWITCH OPERATION AFTER GAIN ADJUSTMENT
In case that it is not possible to enter Full Scale, Parity Calibration can be done by CAL Switch. By CAL Switch, Equivalent Input Change of 1mV/V can be given against the present value. Gain is to be adjusted so that it can get the voltage calculated from Full Scale.

EXAMPLE : In case of a converter rating 1,000 kgf - 2.53 mV/V, you can calibrate to get the output of 10V (20 mA) at 500 kgf as per the following procedures.

- (1) Set the input from Transducer Zero (Non-Load).
Adjust the voltage output (VOL.- G) by Zero-Adjustment Trimmer to make it 0 V.

(2) Adjust the gain by pushing CAL Switch to make Voltage Output
 $10V / (500 \div 1000 \times 2.53mV/V) \approx 7.905V$

When using Current Output, adjust it by monitoring a current output
so that you can get

$$(20mA - 4mA) / (500 \div 1000 \times 2.53mV/V) + 4mA \approx 16.65mA$$

CAUTION

- (1) Analog Conditioner is optional.
- (2) Output Signal is taken out from the point before A/D converting the signal input. It is in proportion to an indicated value, but not the indicated value itself.
Therefore, Output Signal does not coincide with Digital Zero, Auto-Gain, etc. which are digital-processed indicated values.
- (3) Analog Conditioner is not isolated from the internal circuits. Please use a shielded cable to connect to an external equipment. The shielded cable should be not longer than 2 or 3 meters. If a longer cable is used, it will be badly influenced by noises.
- (4) Do not apply voltage from outside. Otherwise, it will be broken.
- (5) Do not make Voltage Output Terminals short-circuited for a longer time than 1 hour. Otherwise, it will cause troubles. If a capacitance load is connected, it might cause a resonance.

25-1-3. ZERO ADJUSTMENT TRIMMER

This trimmer is to adjust a voltage at Voltage Output Terminals so that the voltage becomes Zero when Zero is displayed.

Zero Adjustment Range is $\pm 10\%/FS$ (Approx. $\pm 1V$).

25-1-4. GAIN ADJUSTMENT TRIMMER

This trimmer is to adjust a voltage at Voltage Output Terminals so that the voltage becomes +10V when Full Scale is displayed.

Gain Adjustment Range is $\pm 10\%/FS$ (Approx. $\pm 1V$).

NOTICE

(1) Zero and Gain of D/A Converter are already adjusted before its delivery from our factory.

However, in case of Zero Point Shifting and/or to change the gain, please refer to 25-2 (HOW TO ADJUST D/A CONVERTER).

(2) Voltage Output and Current Output are completely incorporated (i.e. at 10V, 20mA and at 0V, 4mA).

Therefore, you can not adjust independently.

25-1-5. VOLTAGE OUTPUT SIGNAL

Connect an external equipment (Load Resistance $> 2\text{ k}\Omega$) to VOL and G Terminals of TD-310A, as shown in the right.

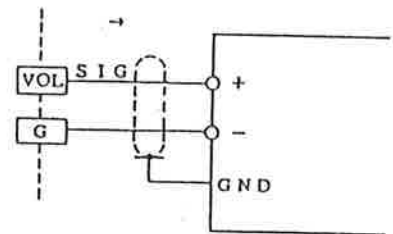

25-1-6. CURRENT OUTPUT SIGNAL

Connect an external equipment (Load Resistance $< 350\Omega$) to CUR and G Terminals of TD-310A, as shown in the right.

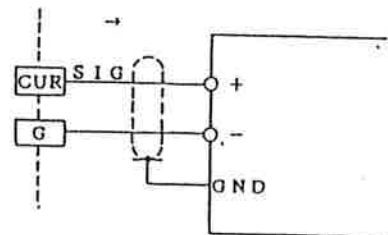

25-1-7. BASIC RESOLUTION

D/A Converter has its basic resolution of 1/3296 against 0 ~ 10V.
There is the following correlation between Digital Indicated Value and Output of Voltage/Current.

EXAMPLE : In case of setting 5,000 as Full Scale (Maximum Value of Digital Display)

Voltage Increase per Step of Display (1/3296) X 10V \approx 3mV	Actual Output Voltage
Current Increase per Step of Display (1/3296) X (20mA - 4mA) \approx 4.9 μ A	Calculated Output Voltage (10V/5000 X Display)
Output Ratio of Digital Indicated Value and Analog (1/3296) X 5000 \approx 1.5	Characteristics of Indicated Value vs Voltage/Current Output

2 Steps Increase of Analog Output per 3 Steps of Indicated Value.

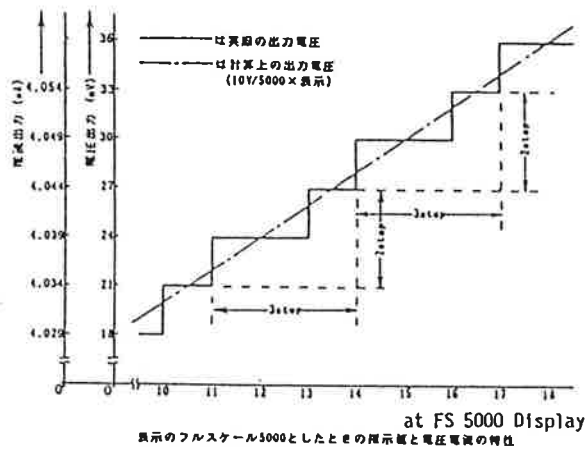

CAUTION

- (1) D/A Converter is optional.
- (2) Do not apply voltage from outside. It causes troubles.
- (3) Do not make Voltage Output Terminal short-circuited for over one hour. It causes troubles.
- (4) Do not connect Capacitance Load which might cause resonance.

25-2. HOW TO ADJUST D/A CONVERTER

Zero and Gain of D/A Converter are already adjusted before shipment from our factory. If you need to make Zero Point Shifting and Change of Gain you can adjust them as follows.

(Voltmeter and Ammeter with accuracy of 1/10,000 are to be needed.)

25-2-1. ACTUAL LOAD CALIBRATION

Adjustments can be carried out to supply an actual load or a dummy load of Calibrator Model 513B of Full Scale to Transducer.

EXAMPLE : By using Transducer rating 500 kgf, 2.050 mV/V, adjust a display value at 2.050 mV/V so that it can be calibrated to 500.0 as follows.

- (1) Supply an appropriate Input to make a display Zero and then adjust Zero Adjustment Trimmer so that Voltage Output (VOL.-G) becomes 0V.
- (2) Supply an appropriate Input to make a display 500.0 and then adjust Gain Adjustment Trimmer so that Voltage Output (VOL.-G) becomes 10V

When Current Output is used, connect Ammeter to Current Output (CUR.-G) and then adjust Current Output so that 4 mA can be measured at (1) and 20 mA at (2) above.

25-2-2. CALIBRATION BY CALCULATION

In case it is not possible physically to apply Full Scale Value and to adjust it at Input of Full Scale, a calibration can be carried out by calculation on basis of a reference value as follows.

EXAMPLE : Supposing calibration was made so that 500.0 is now displayed at input of 2.050 mV/V, and a load is applied for Gain Adjustment, 1232 is displayed, in this case Analog Output would be :

(1) VOLTAGE OUTPUT : $(1232/5000) \times 10V \approx 2.464V$

(2) CURRENT OUTPUT : $(1232/5000) \times (20mA - 4mA) + 4mA \approx 7.942mA$

Gain should be adjusted so that Voltage Output can be 2.464V or Current Output be 7.942mA.

By this if Input of 2.050mV/V is actually supplied and 500.0 is displayed, Analog Output is to be approx. Full Scale (10V, 20mA).

26) MULTIPLE HIGH/LOW LIMIT COMPARISON (OP-8, TD-3108)

26-1.

Eight types of high and low limit value can be stored and selected by external input.

26-1-1. Entry of eight high limit values.

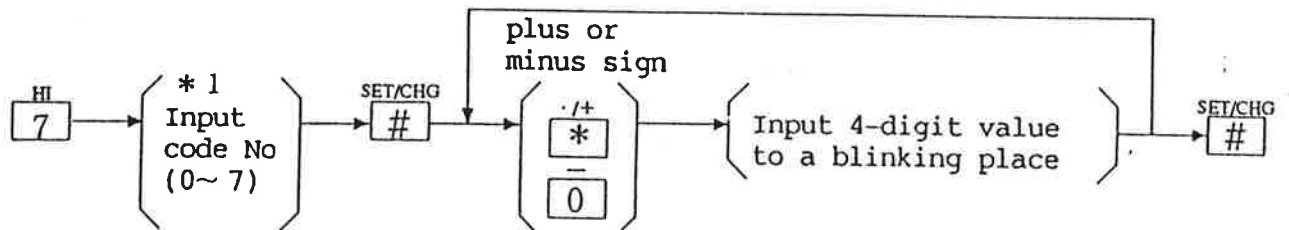

* 1

After 'H-[code No.]' is displayed for a second, an entered value corresponding to the code No. is displayed.

26-1-2. Entry of eight low limit values.

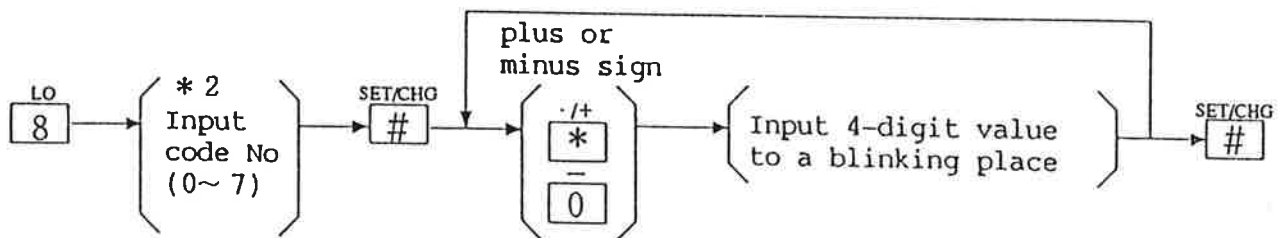

* 2

After 'L-[code No.]' is displayed for a second, an entered value corresponding to the code No. is displayed.

Entered high and low limit values are stored in the NOV RAM (non-volatile memory) so that they will not be cancelled in case of power failure.

When the high/ low limit value is re-entered by the RS-232C (Option 2), the re-entered value becomes effective.

26-2. Entry of high/low limit values by external selection

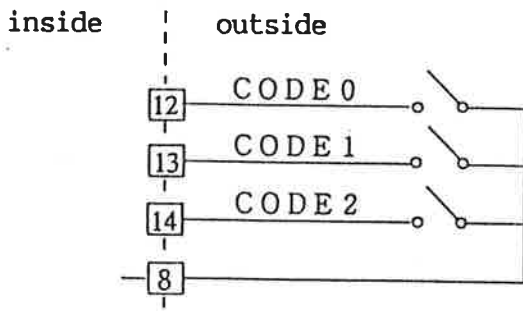

External selection is carried out by combination of three code No. inputs.

code No	CODE 0	CODE 1	CODE 2
0	0	0	0
1	1	0	0
2	0	1	0
3	1	1	0
4	0	0	1
5	1	0	1
6	0	1	1
7	1	1	1

0 : OPEN
1 : CLOSE

26-3. Input interface.

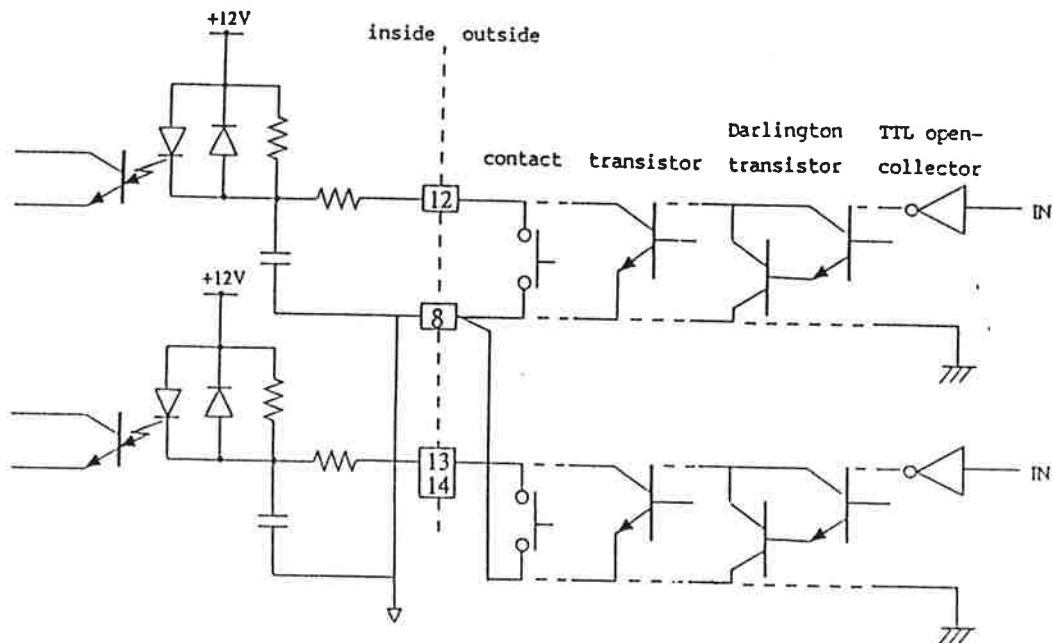

26-4. BCD Output

TD-3108 have a BCD code output to be based option TD-3103.

26-5. OUTPUT CONNECTOR PIN ASSIGNMENT :

1	C	O	M	2 6	C	O	M
2	Data	1	Output	2 7	Code No.1	Input	
3	"	2	"	2 8	code No.2	Input	
4	"	4	"	2 9	Code No.3	Input	
5	"	8	"	3 0			
6	"	1 0	"	3 1			
7	"	2 0	"	3 2			
8	"	4 0	"	3 3			
9	"	8 0	"	3 4			
1 0	"	1 0 0	"	3 5			
1 1	"	2 0 0	"	3 6			
1 2	"	4 0 0	"	3 7			
1 3	"	8 0 0	"	3 8			
1 4	"	1 0 0 0	"	3 9			
1 5	"	2 0 0 0	"	4 0			
1 6	"	4 0 0 0	"	4 1			
1 7	"	8 0 0 0	"	4 2	Minus	(POLARITY)	
1 8				4 3			
1 9				4 4			
2 0				4 5			
2 1				4 6	OVER	OUTPUT	
2 2				4 7			
2 3				4 8			
2 4				4 9	EOC	(CONVERSION FINALIZED)	
2 5				5 0	BCD HOLD	INPUT	

☆ Output Connector : 57-40500 (DDK Made)

☆ Open Pins are internally used, and, therefore, they should not be connected outside.

26-6. SIGNAL LOGIC

- (1) BCD DATA OUTPUT : Negative Logic / Positive Logic
(To be specified when ordering)
- (2) POLARITY OUTPUT : Negative Logic (When Minus, "L")
- (3) OVER OUTPUT : Negative Logic (When Over, "L")
- (4) EOC (CONVERSION FINALIZED) : Negative Logic
- (5) BCD HOLD INPUT : Negative Logic (When "L", BCD Data Hold)

27) SELF-CHECK

TD-310A has its own Automatic Self-Check (Self-Diagnosis) function for the internal circuits and the programmed contents and then displays the results for the visual confirmation.

27-1. SELF-CHECK PROCEDURE

27-1-1. Self-Check can start by Key-Switch operation in the front panel.

Push Key-Switch as follows.



Then, TD-310A starts immediately the checks.

27-1-2. CHECK-ITEM AND DESCRIPTION

CHECK SEQUENCE	DISPLAY	CHECK DESCRIPTION	MEANS	REQUIRED TIME
1	FFFF	Start	Display	1 Sec.
2	EL	Status LED	Eye Visual	2 Sec.
3	Figure	Figure LED	Eye Visual	4 Sec.
4	EL ²	Interrupt Circuit	Auto.	0.1 Sec.
5	EL ³	A/D Converting	Auto.	0.1 Sec.
6	EL ⁴	RAM	Auto.	0.3 Sec.
7	EL ⁵	ROM	Auto.	6 Sec.
8	1.00	Soft-Ware Version	Display	1 Sec.
9	PASS	End of Check	Display	2 Sec.

27-1-3. CHECK SEQUENCE 1

Digital Panel Meter shows "FFFF" for about 1 second, which indicates the start of Check.

27-1-4. CHECK SEQUENCE 2

Status Display LED shall be checked visually by eyes as per the following steps.

Lighting Order is followed in the arrow.

Each lighting lasts about 0.3 second.

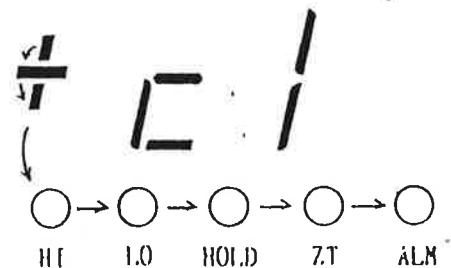

27-1-5. CHECK SEQUENCE 3

Figure Display LED shall be checked visually by eyes.

Lighting is in order as follows.

Decimal Point Display : 9 → 8 → 7 → 6 → 5 → 4 → 3 → 2 → 1 → 0

• → • → • → •	5 → 5 → 5 → 5
	4 → 4 → 4 → 4
9 → 9 → 9 → 9	3 → 3 → 3 → 3
8 → 8 → 8 → 8	2 → 2 → 2 → 2
7 → 7 → 7 → 7	1 → 1 → 1 → 1
6 → 6 → 6 → 6	0 → 0 → 0 → 0

27-1-6. CHECK SEQUENCE 4 - 7

After 1 second later, Checks are carried out Check Sequence 4 to 7 in order automatically. Check Description is shown in the Display.

27-1-7. CHECK SEQUENCE 8

Soft-Ware Version is displayed for about 1 second.

For example, if "1.00" is displayed, it indicates the soft-ware version is V1.00.

27-1-8. CHECK SEQUENCE 9

Figure Display shows "PASS", which indicates No-Troubles found by the checks.

27-2. WHEN TROUBLES FOUND

During the visual checks of Check Sequence 2 and 3, if Condition Display LED does not turn on or Figure Display does not indicate figures properly or during Check Sequence 4 to 7, if each check does not finish in the time required for each check, there must be some troubles in

TD-300A and you are requested to report to it us or our agent from whom you purchased from for the repair.

CAUTION

Self-Check can be done anytime, but while self-checking, Upper/Lower Limit, Peak-Hold, etc. are all interrupted.

28) BLOCK DIAGRAM

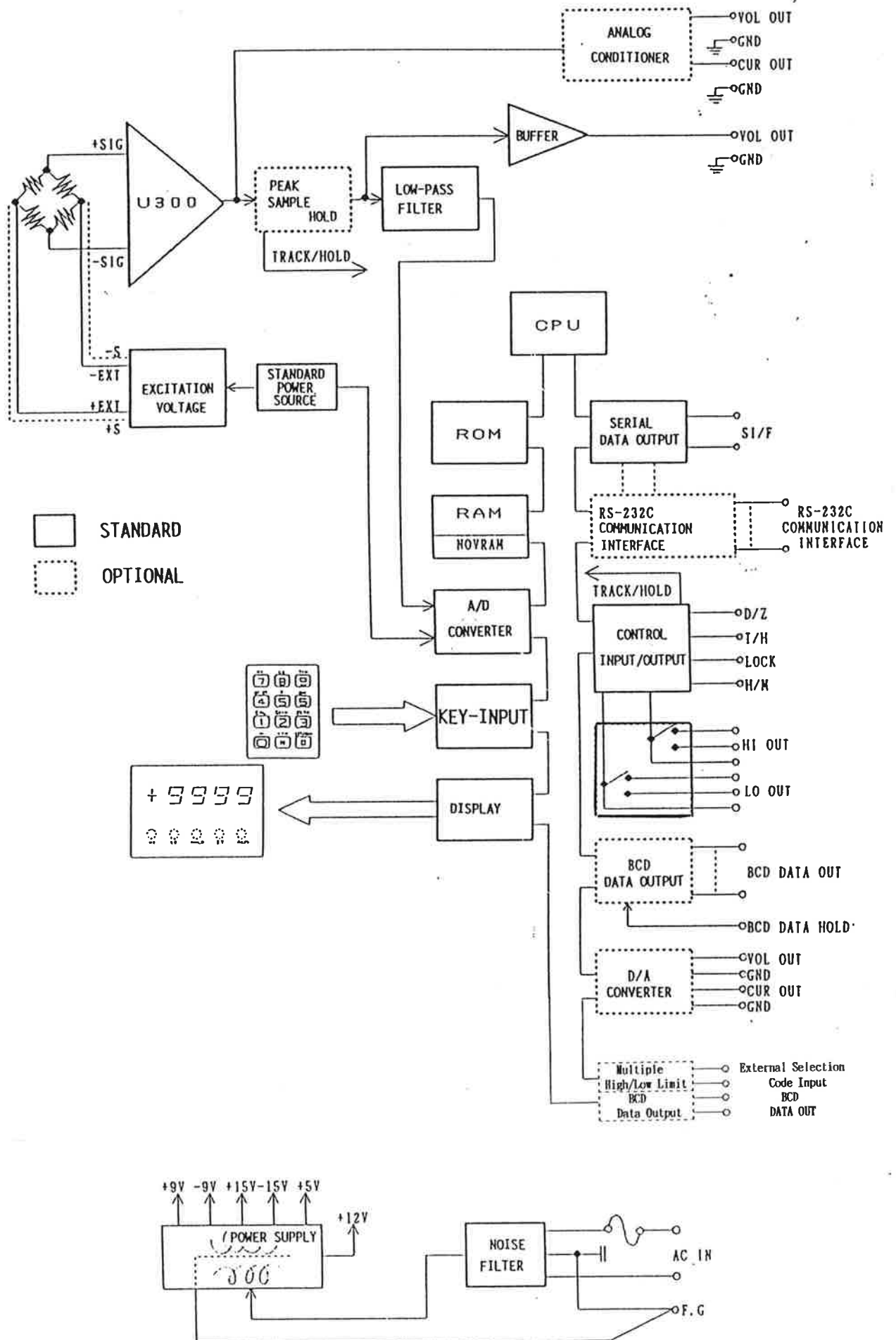

29) SYSTEM DIAGRAM

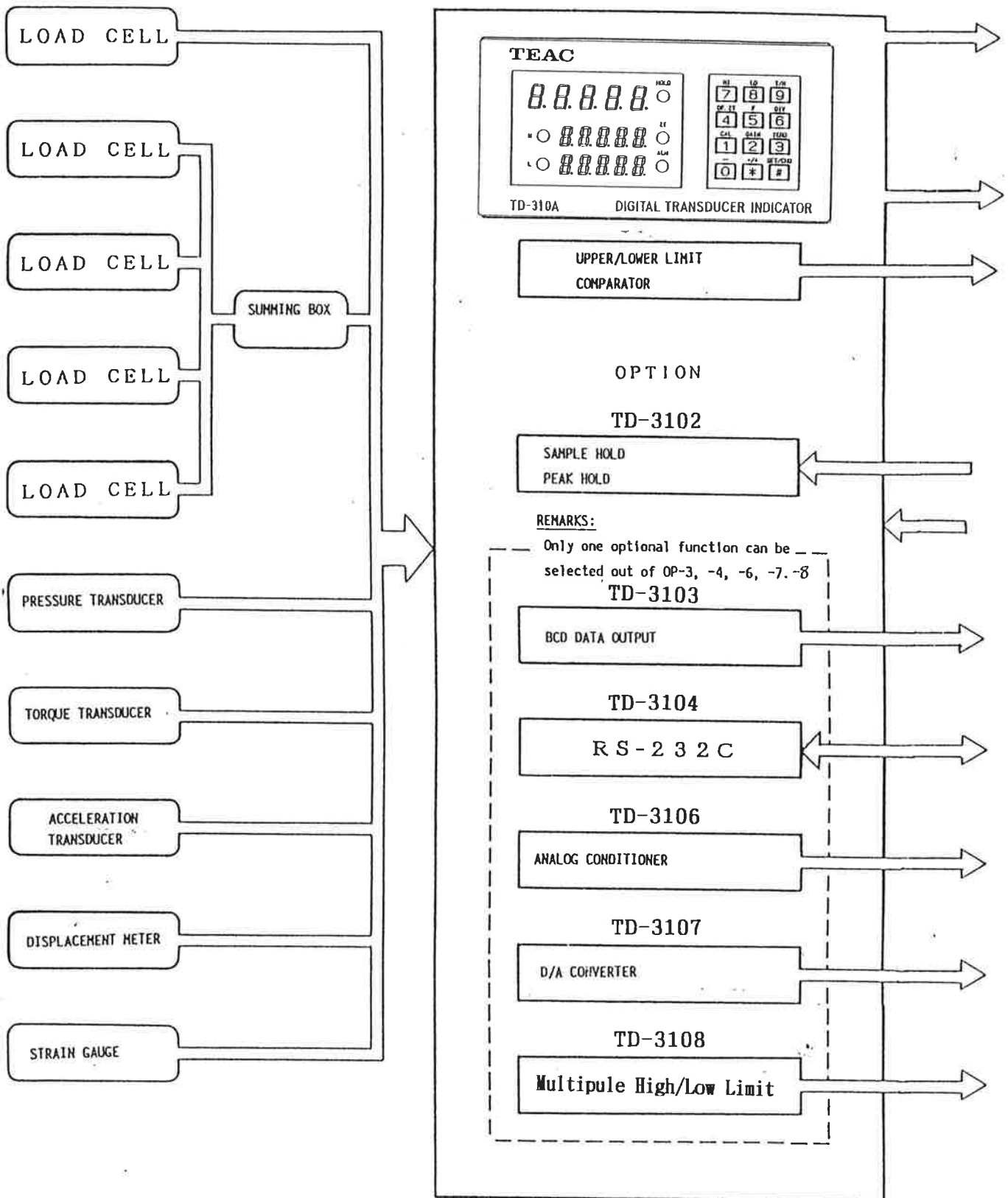

3 0) S P E C I F I C A T I O N S

30-1. STANDARD SPECIFICATIONS

- 30-1-1. BRIDGE EXCITATION : DC 10V, DC 5V, DC 2.5V Selective by Switch
Output Voltage 120mA Max.
Connection System : 4 Wire / 6 Wire
(Remote sensing)
- 30-1-2. SIGNAL INPUT RANGE : 0.5mV/V - 3.2mV/V (1.6 μ V/D)
- 30-1-3. ZERO/GAIN ADJUSTMENT : Automatic Adjustment System by Internal Cal.
- 30-1-4. EQUIVALENT CALIBRATION
INPUT SETTING RANGE : 0.500mV/V - 3.200mV/V
ERROR : 0.1% FS Max.
(Calibration Value (mV/V) Input by Ten-Key and
Equivalent Value Input can be converted to
an indicated value.)
- 30-1-5. DISPLAY : ± 0000 - ± 9999 , Character Height 10mm,
Red LED, LSD can be made as Dead Zero.
- 30-1-6. DECIMAL POINT : Any point to be set.
- 30-1-7. DISPLAY FREQUENCY : About 15 Times per Second
- 30-1-8. ACCURACY : T.C. ZERO : 0.25 μ V/ $^{\circ}$ C RTI Max.
T.C. GAIN : 0.01%/ $^{\circ}$ C Max.
NOISE : 0.20 μ Vp-p RTI Max.
NON-LINEARITY : 0.03%FS ± 1 digit
(at 0.5mV/V Input)
- 30-1-9. SERIAL DATA OUTPUT : SI/F
(F Series Original Designed Serial Interface)
Transmission System: Start-Stop Synchronous
Transmission Speed : 600 BPS
- 30-1-10. ANALOG VOLTAGE OUTPUT: Voltage Output in proportion to Signal Input
(Voltage Output can be in HOLD in case of with
OP-2 PEAK-HOLD)
Output Level : About 2V per Input 1mV/V
Load Impedance: 5k Ω Min.
- 30-1-11. DIGITAL ZERO : Make Displayed Value Zero by Key-Switch or
by External Signal.

30-1-12. UPPER/LOWER LIMIT COMPARATIVE FUNCTION

PRESETTING RANGE : 0000 - ± 9999 by Ten-Key in the front panel

PRESETTING OUTPUT: Relay Contact Output (1T)

Contact Capacity AC 250V, 0.5A
(at Resistance Load)

HYSTERESIS : Setting Range 0000 - 9999 to be set by
Ten-Key for Hysteresis at OFF Time.

30-1-13. ZERO TRACKING : Compensating Zero Drifts of Transducer and
Amplifier. Range Selection Available.

30-1-14. DIGITAL FILTERING : Make Indicated Values stabilized by Digital
Calculation. Range Selection Available.

30-1-15. DIGITAL TARE SUBTRACTION : Set Tare Value at Key-Switch and Subtract it
from the indicated value in the range between
0000 - ± 9999

30-1-16. INPUT POWER SYSTEM : AC 100V $\pm 10\%$, 50/60Hz, About 14VA

30-1-17. OPERATION CONDITIONS : TEMPERATURE: -10 to +40°C

HUMIDITY : 80% RH Max. (No-Dewing)

30-1-18. EXTERNAL DIMENSION : 144W X 72H X 180D mm

30-1-19. WEIGHT : About 2.2 kgs

30-2. OPTIONAL FUNCTIONS (ONLY ONE SELECTIVE OUT OF OP-3, -4, -6, -7, -8)

30-2-1. OP-2 SAMPLE-HOLD / PEAK-HOLD FUNCTION (ANALOG/DIGITAL TYPE) (TD-3102)

RESPONSE : About 10kHz

(Standard Type has CR Filter of about
1kHz/-3dB in the prior stage of PEAK-HOLD
Circuit.)

ACCURACY : 0.1%/FS Max.

MODE SWITCH : TRACK/HOLD selectable by Key-Switch in the
front panel or by External Input.

30-2-2. OP-3 BCD DATA OUTPUT (TD-3103)

OUTPUT SYSTEM : Isolated Open Collector Output

DRIVING CAPACITY : 30V, 20mA

30-2-5. OP-7 D/A CONVERTER (TD-3107)

ANALOG OUTPUT VS : Gain set by Key Board becomes Full Scale
DISPLAY VALUE of Analog Output.

Full Scale of D/A can be set separately
from Gain.

ZERO ADJUSTMENT : $\pm 10\%/FS$

RANGE

GAIN ADJUSTMENT : $\pm 10\%/FS$

RANGE

NON-LINEARITY : 0.1%/FS

RESPONSE : 15 Times/Sec. A/D Converting Speed.

WITHSTAND VOLTAGE: AC 500V

VOLTAGE OUTPUT : 0- +10V $RL > 2k\Omega$ (Unipolar)

CURRENT OUTPUT : 4-20mA $RL < 500\Omega$ (4-20mA to be obtained
at Voltage Output 0- +10V)

OUTPUT TERMINAL : Terminal Board with Cage Clamp System

30-2-6. OP-8 MULTIPLE HIGH/LOW LIMIT COMPARISON (TD-3108)

PRESETTING RANGE : 0000- 9999 by Ten-key in the front
panel

CODE : Up to 8 codes

CODE SELECTION : External input (3 digits)

PRESETTING OUTPUT : Relay Contact Output (1T)